



Moveco®, fondata nel 1988 nella propria sede di Grignasco (NO), progetta, produce e collauda attuatori rotanti e componenti oleodinamici. Nel 2001 ha ottenuto la certificazione ISO9001/VISION 2000, a coronamento di un lungo lavoro di miglioramento dei propri prodotti e processi produttivi, commerciali e gestionali.

Maestranze altamente specializzate e motivate consentono di proporre alla clientela prodotti innovativi, di alta qualità ed a costi competitivi. Un'organizzazione Commerciale attenta alle esigenze del cliente, un Ufficio Tecnico informatizzato ed efficiente, un reparto Macchine Utensili tecnologicamente avanzato e moderni sistemi di misura e collaudo permettono alla Moveco® di affrontare con sicurezza e successo le sfide quotidiane di un mercato sempre più competitivo ed esigente. L'accordo di collaborazione con HYDRAFORCE® rende possibile l'impiego della loro gamma di valvole a cartuccia sia di tipo tradizionale sia proporzionale, per la realizzazione di circuiti oleodinamici completi.

Moveco® progetta e realizza i seguenti prodotti:

- attuatori rotanti idraulici elicoidali in una completa gamma di versioni standard e speciali.
- martinetti idraulici di differenti tipologie, alesaggi e corse, a semplice e a doppio effetto.
- manifolds o circuiti integrati, per il comando e controllo di attrezzature specifiche per applicazioni industriali e mezzi mobili.



Moveco®, established in 1988 in its own premises in Grignasco (NO), designs, manufactures and tests rotary actuators and oil-pressure components. In 2001 the company obtained the ISO9001/VISION 2000 certification, as a crowning achievement of long and steady efforts aimed at improving its products as well as its manufacturing, commercial and management processes.

Its highly qualified and skilled staff allows the Company to offer innovative, high-quality and competitive products. Customer-oriented sales department, computerized and efficient engineering department, its technologically updated machinery and its modern and reliable measuring and testing instruments enable Moveco® face the daily challenges of a more and more competitive and demanding market. The agreement with HYDRAFORCE® allows the company to use this company's range of both traditional and proportional cartridge valves for the development of complete oil-pressure circuits.

Moveco® designs and manufactures the following products:

- rotating hydraulic helical actuators in a full range of standard and special versions.
- hydraulic jacks of different types, bores and strokes with single or double effect.
- manifolds or integrated circuits, for the operation and control of specific equipments for industrial and mobile applications.



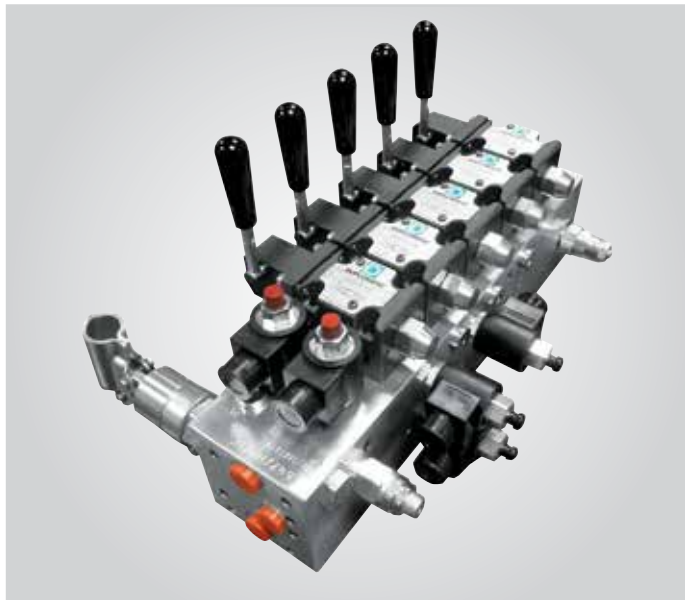

Dani-tech A/S
Bredholm 4 DK-6100
Haderslev

Dani-tech BV
Energieveg 41/A NL-2382 NC Zoeterwoude
www.dani-tech.com

Phoenix Marine Solutions
21, Wainman Road, Woodston
Peterborough, Cambs PE2 7BU
www.phoenixmarinesolutions.co.uk

PSI
Provence Services Industrie
515 Chemin de l'Oratoire de Bouc
13120 Gardanne (F)
www.provence-services-industrie.com

HYDRACOM GmbH
Falkenberger Weg 38
40699 Erkrath
Tel. 02104 9570160
Fax 02104 9570162
www.hydra.com.de

HIDROKONTROL
Mak.San.Tic.A.S.
Melih Gokcek Bulvari No.8
Ivedik OSB 06378 Ankara - Türkiye
www.hidrokontrol.com.tr

Shanghai Hugo IND Co., Ltd.
Room 903-905, No.1, 58
Guangtong Road,
Minhang District, Shanghai
www.sh-hugo.cn

Young Powertech, Inc.
3060 Plaza Drive, Unit 107
Garnet Valley, PA 19060
www.youngpowertech.com



DESCRIZIONE

Il concetto operativo degli attuatori rotanti idraulici progettati e costruiti da Moveco è molto semplice: il movimento assiale del pistone è convertito in movimento rotatorio per mezzo di due coppie di dentature elicoidali, una ricavata tra pistone e boccola dentata, l'altra tra albero e pistone.



CARATTERISTICHE PRINCIPALI Disegno compatto e funzionale

La corsa limitata del pistone, abbinata ad un elevato angolo del profilo elicoidale che consente di ridurre la dimensione dell'attuatore, il trafilamento nullo, le guarnizioni in PTFE, poliuretano e gomma nitrilica, i cuscinetti a rullini per diminuire l'attrito ed il gioco angolare ridotto sono solamente alcune delle caratteristiche principali che permettono agli attuatori Moveco di essere particolarmente pratici e di semplificare molti sistemi tradizionali di rotazione.

Cuscinetti ad alto rendimento e per impieghi gravosi

Gli attuatori adottano cuscinetti a rullini che consentono di diminuire gli attriti permettendo di incrementare il rendimento globale senza alterare la resistenza ai carichi assiali; pattini in resina fenolica vengono utilizzati per sostenere i carichi radiali. Alcune tipologie sono in grado di sopportare elevati momenti ribaltanti, evitando di dover installare supporti rotanti aggiuntivi.

Albero in unico pezzo con foro passante, quando richiesto

L'albero di torsione è in lega d'acciaio ad alta resistenza. Può essere forato diventando più leggero ed ampliando così il campo di utilizzo. Il foro può essere sfruttato per l'applicazione di un tirante supplementare per una maggior sicurezza, specialmente in presenza di carichi critici, oppure può consentire il passaggio di tubi flessibili e/o cavi elettrici.

Montaggio diretto dell'attuatore sull'elemento mobile

Il fissaggio dell'attuatore si può ottenere mediante dei fori filettati ricavati sull'albero e sulla flangia opposta oppure un albero maschio o femmina con linguette o profili scanalati. Entrambe le soluzioni garantiscono un'unione sicura e priva di giochi.

Modelli personalizzati

Oltre a tutta una serie di modelli standard, è possibile realizzare soluzioni personalizzate in accordo con le esigenze del cliente, quali angoli di rotazione dedicati, sistemi di fissaggio personalizzati del corpo e dell'albero, frenatura, regolazione esterna dell'angolo di rotazione, versioni in acciaio inox o con verniciature e trattamenti superficiali speciali.



DESCRIPTION

The operating concept of the hydraulic rotary actuators designed and manufactured by Moveco is simple: the linear piston motion is converted into a rotation movement by twin helical gears, the first between the piston and the splined bushing, the second matching helical gears between the shaft and the piston.



MAIN FEATURES

Compact units with functional efficiency

The short stroke of the piston with a high angle of the helical gears provides a compact size of the actuator. PTFE, NBR, polyurethane seals, no leakage, roller bearings to reduce friction, reduced backlash, allows the hydraulic rotary actuators made by Moveco to replace and to turn easy many traditional systems.

High efficiency heavy duty bearings

Moveco actuators incorporate integral roller bearings assuring reduced friction and higher functional efficiency, not affecting the resistance to the thrust capacity. Guide rings in phenolic resins are used to support radial loads. Specific items are made to support high bending moment, without additional outside thrust-bearings.

Shaft machined in one piece and with through bore, when required.

The shaft is machined from high resistance alloy steel. The bore reduces the weight and allows to put a safety tie-rod for specific loads, or it can be useful to go through with hydraulic hoses or electrical wiring.

Direct installation of the actuator on the mobile unit

By mounting flange with threaded holes opposite to the shaft. By male or female shaft with keys or splined connections. Both solutions assure a tight reliable junction without backlash.

Custom made models

Besides a range of standard elements, it is possible to realize special item to meet specific requirements, like custom made fastening systems of the shaft and body, specific rotation angles, cushioning, special shaft and housing configuration, external adjustment of the rotation angle.

Special versions made in Stainless Steel or with protection and thermic treatments are available for in hard environments as well as marine applications.



Gioco angolare

Oltre alle tolleranze di lavorazione intervengono la compressibilità dell'olio e la deformazione delle guarnizioni sotto l'effetto della pressione. Il valore standard è $\pm 20'$ di grado, a richiesta è possibile ottenere $\pm 10'$ di grado.

La coppia

La coppia è funzione lineare della pressione del sistema. Le aree del pistone sono uguali e pertanto l'attuatore produce una coppia uguale sia ruotando in senso orario, sia in senso antiorario. La coppia utile tende a diminuire con l'aumentare del momento ribaltante, ma l'impiego di cuscinetti a rullini permette di limitare questo fenomeno.

Condizioni di sicurezza

a) Temperature d'esercizio

In presenza di una elevata frequenza di cicli di lavoro si possono verificare condizioni di riscaldamento eccessivo che rischiano di danneggiare le guarnizioni. Si raccomanda, quindi, di rispettare le temperature indicate a catalogo e, in caso di necessità, di provvedere al raffreddamento dell'olio.

b) Velocità eccessiva di rotazione

In presenza di elevate velocità di rotazione la decelerazione angolare, in fase di frenatura, può indurre dei carichi inerziali che superano la coppia nominale alla massima pressione. Quando questi momenti inerziali sono due volte superiori della coppia massima, bisogna applicare al sistema valvole di decelerazione e fine corsa esterni.

Attacco a forcella

Straddle mounting

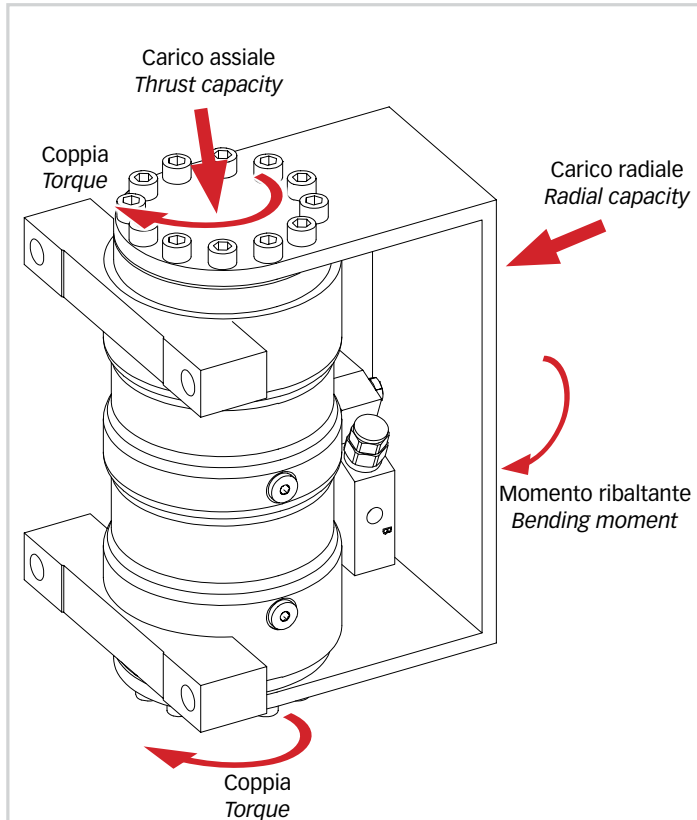

Backlash

The backlash is due to the manufacturing tolerances as well as the fluid and seals compression. In Moveco actuators the standard backlash is more or less $20'$ of degree. On request it is possible to get more or less $10'$ of degree.

Output Torque

The torque is a linear function of the pressure of the system. Hydraulic rotary actuators generate very high torque in small units. Since the areas of the piston are equal both sides, the actuator gives the same torque for both clockwise and counter-clockwise rotation. The output torque is affected by the bending moment capacity. Moveco use roller bearings to limit the decrease of the torque output due to the increase of the moment required.

Safety Conditions

a) High Frequency of work Cycles

can cause the raise of heating condition with the risk of seals failure. The mechanical movements dissipates energy as heat. It is recommended to stay within the range of temperatures indicated in the catalogue. In case take care to cool down the oil.

b) High Speed Rotation

When high speed of rotation occurs, the angular slow down, during braking, can raise inertial loads higher than the nominal torque at the max pressure. When those inertial moments exceed twice the max torque value, it is necessary to install within the system valves of deceleration and limit switches outside the actuator.

Attacco a sbalzo

Cantilever mounting

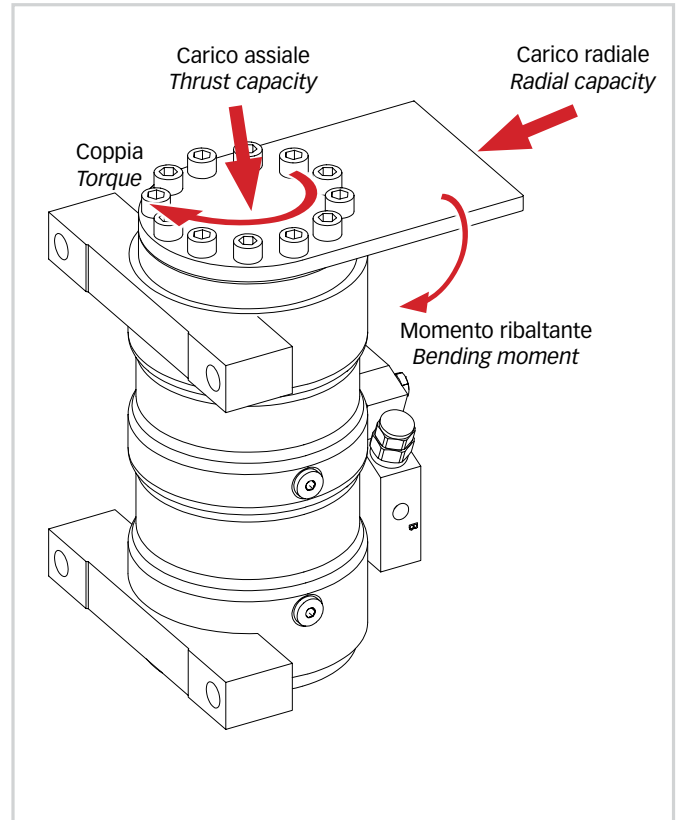



VALVOLA OVERCENTER PARTE INTEGRANTE DELL'ATTUATORE

La valvola overcenter doppia è costituita da due cartucce incorporate in un blocco in lega d'alluminio fissato sul corpo dell'attuatore oppure avvitate direttamente in esso. La valvola assicura un movimento regolare della rotazione dello stesso e lo blocca in posizione quando richiesto.



OVERCENTER VALVE IS AN INTEGRAL PART OF THE ACTUATOR

The double overcenter valve is made by two cartridges fitted in an aluminum body, then fixed on the actuator or screwed directly onto it.

The valve ensures a smooth movement of the rotation and locks it in a fixed position when required.

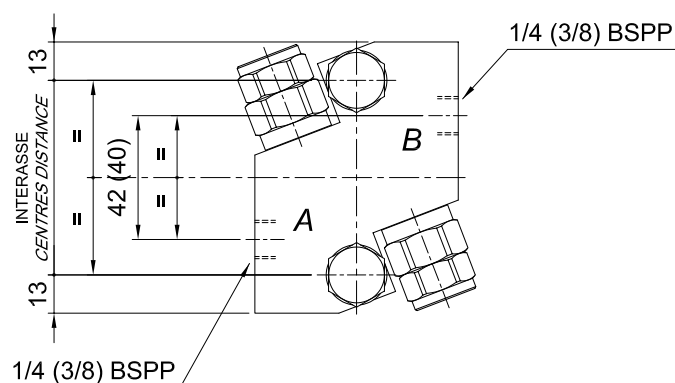
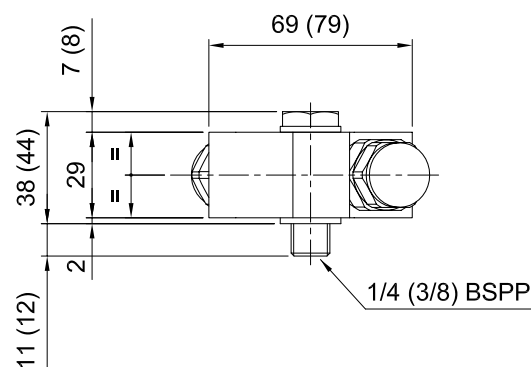
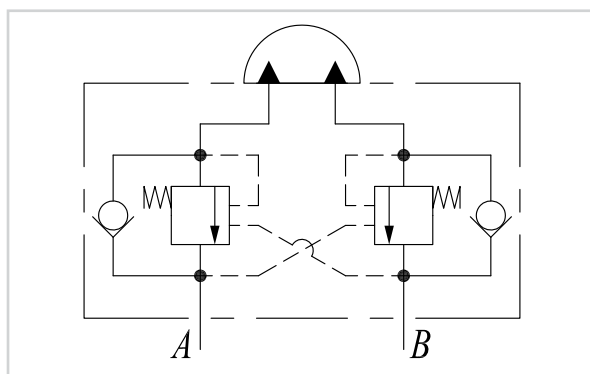

I dati si riferiscono alla versione con attacchi da 1/4 BSPP; tra parentesi sono indicati i valori per 3/8 BSPP.

Data refer to the version with 1/4 BSPP ports; the values in brackets are for model 3/8 BSPP.



interasse fori fissaggio attuatore	058, 066, 075, 092, 095, 110, 126, 136, 140
taratura overcenter	V= regolabile 60÷220 bar W= regolabile 100÷350 bar L= fissa 90 bar M= fissa 120 bar N= fissa 150 bar P= fissa 180 bar T= fissa 210 bar (standard) X= fissa 250 bar
rapporto di pilotaggio	A= 1:4 (standard) B= 1:8
tipo di overcenter	C= bilanciata in aria K= non bilanciata in aria (standard)
tipo di bullone cavo	S= con strozzatore unidirezionale Z= senza strozzatore unidirezionale



centres distance of fastening holes	058, 066, 075, 092, 095, 110, 126, 136, 140
overcenter valve setting	V= adjustable 60÷220 bar W= adjustable 100÷350 bar L= fixed 90 bar M= fixed 120 bar N= fixed 150 bar P= fixed 180 bar T= fixed 210 bar (standard) X= fixed 250 bar
piloting ratio	A= 1:4 (standard) B= 1:8
kind of overcenter valve	C= balanced in the open air K= not balanced in the open air (standard)
kind of hollow bolt	S= with unidirectional control flow Z= without unidirectional control flow

esempio / example

W.765/B

interasse / centres distance

taratura overcenter / overcenter valve setting

tipo di bullone cavo / kind of hollow bolt

tipo di overcenter / kind of overcenter valve

rapporto di pilotaggio / piloting ratio

VALVOLA OVERCENTER OVERCENTER VALVE



Blocco con doppia valvola overcenter (1-2) oppure doppio ritegno pilotato (3) da flangiare direttamente sull'attuatore.



Manifold with double overcenter valve (1-2) or double piloted check valve (3) to be flanged directly on the actuator.

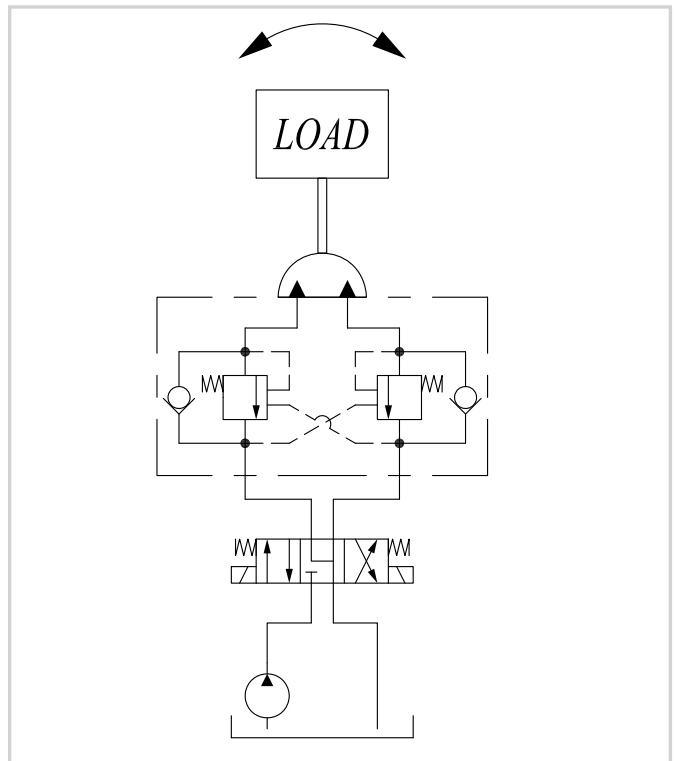

ARC 16 - RC.15/...

ATTUATORE ROTANTE
ROTARY ACTUATOR

H. MOVECO
ROTARY ACTUATORS
HYDRAULIC COMPONENTS



APPLICAZIONI PIU' COMUNI

Rotazione bracci per spazzole su macchine pulizia stradale e del cesto su piattaforme aeree; attuatore adatto a supportare momento ribaltante a forcella od a sbalzo; applicazione più comune ad asse verticale.



STANDARD APPLICATIONS

This type of actuator can support a bending moment, cantilever or straddle mounting; normally used on vertical axle for arms rotation on sweeper brushing-machines, suitable also to rotate the basket on aerial platforms.





angolo di rotazione	standard 180° a richiesta: 360°
cilindrata	295 cm ³ (594 cm ³)
coppia attiva massima a 210 bar	1200 Nm
coppia passiva massima a 210 bar	1850 Nm
pressione massima	210 bar
pressione di collaudo	320 bar
carico assiale massimo	40000 N
carico radiale massimo	40000 N
momento ribaltante massimo con attacco a forcella	-
momento ribaltante massimo con attacco a sbalzo	6900 Nm
peso	33 kg (42 kg)
materiale guarnizioni	PTFE- NBR - Poliuretano
temperatura	da -20°C a +80°C
valvola overcenter	vedi scheda relativa

I dati si riferiscono alla versione con 180° di rotazione; tra parentesi sono indicati i valori per il 360°

Per maggiori dettagli tecnici consultate il nostro sito www.movecosrl.com
 Moveco si riserva la possibilità di apportare modifiche senza preavviso.

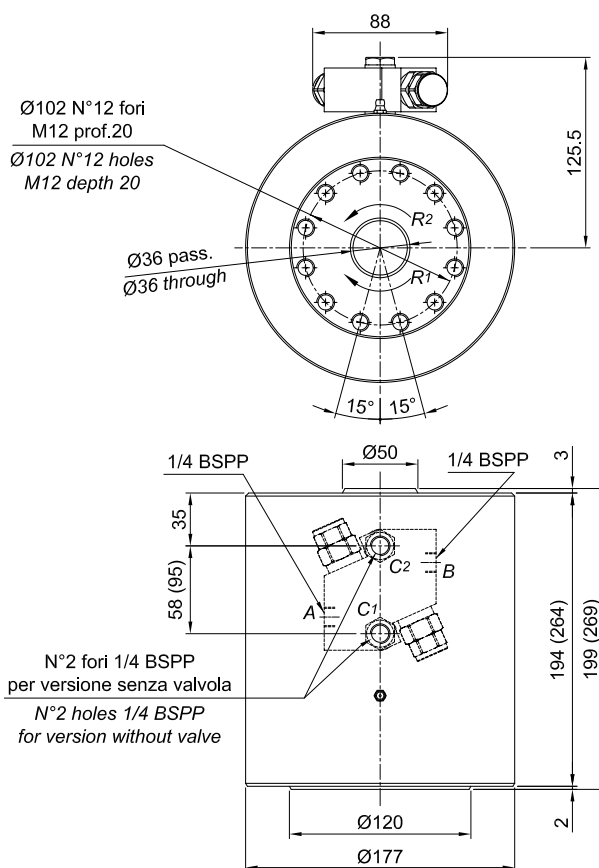

rotation	standard 180° special 360°
displacement	295 cm ³ (594 cm ³)
maximum drive torque at 210 bar	1200 Nm
maximum holding torque at 210 bar	1850 Nm
maximum pressure	210 bar
test pressure	320 bar
maximum thrust capacity	40000 N
maximum radial capacity	40000 N
max moment capacity straddle mounting	-
max moment capacity cantilever mounting	6900 Nm
weight	33 kg (42 kg)
seals	PTFE- NBR - Polyurethane
working temperature	from -20°C to +80°C
overcenter valve	see specific datasheet

Data refer to the version with 180° rotation; the values in brackets are for model 360°

For more technical details please visit our site www.movecosrl.com
 Moveco can modify the technical details without notice.

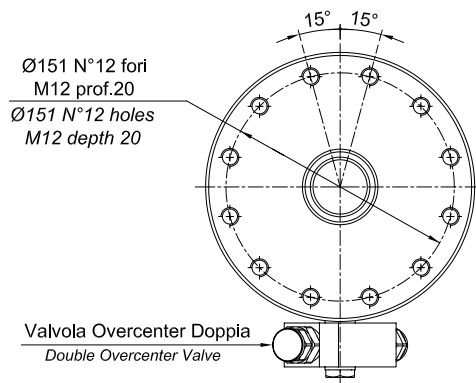

Valvola Overcenter Doppia
Double Overcenter Valve

P in A / C1 = Rot. R1 P in B / C2 = Rot. R2

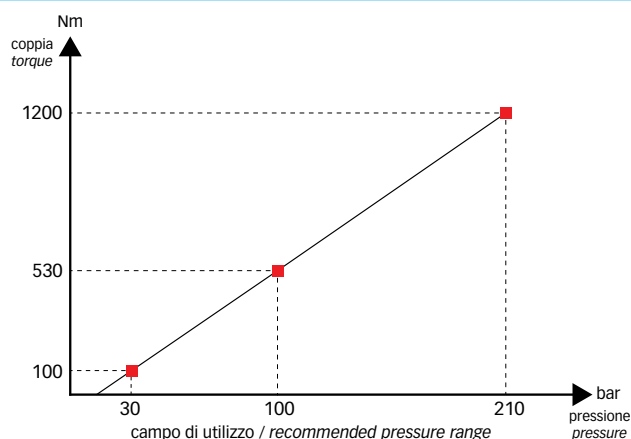

ARC 55 - RC.27/...

ATTUATORE ROTANTE
ROTARY ACTUATOR



APPLICAZIONI PIU' COMUNI

Rotazione gruette girevoli e telescopiche o passerelle multifunzionali che comprendono anche la funzione di gruette; attuatore adatto a supportare momento ribaltante a sbalzo; applicazione più comune ad asse verticale.



STANDARD APPLICATIONS

This actuator is suitable to support a bending moment straddle mounting; mostly used on vertical axle for the rotation of slewing cranes and telescopic cranes, as well as multifunctional gangways used also for the crane function.





angolo di rotazione	standard 270°
cilindrata	1086 cm ³
coppia attiva massima a 210 bar	2955 Nm
coppia passiva massima a 210 bar	4550 Nm
pressione massima	210 bar
pressione di collaudo	320 bar
carico assiale massimo	70000 N
carico radiale massimo	70000 N
momento ribaltante massimo con attacco a forcella	-
momento ribaltante massimo con attacco a sbalzo	26000 Nm
peso	78 kg
materiale guarnizioni	PTFE- NBR - Poliuretano
temperatura	da -20°C a +80°C
valvola overcenter	vedi scheda relativa

Per maggiori dettagli tecnici consultate il nostro sito www.movecosrl.com
 Moveco si riserva la possibilità di apportare modifiche senza preavviso.

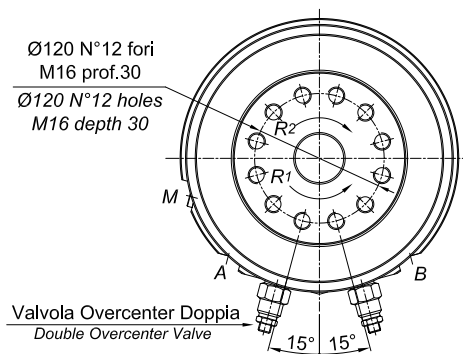
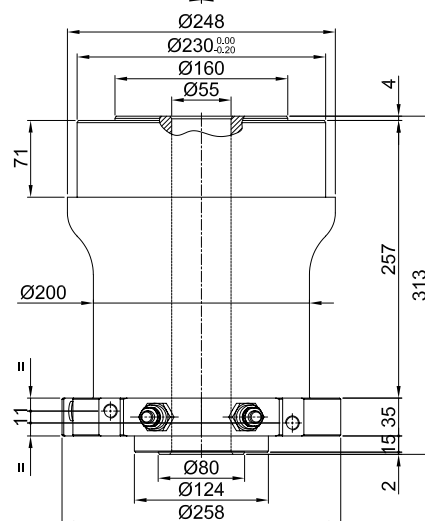
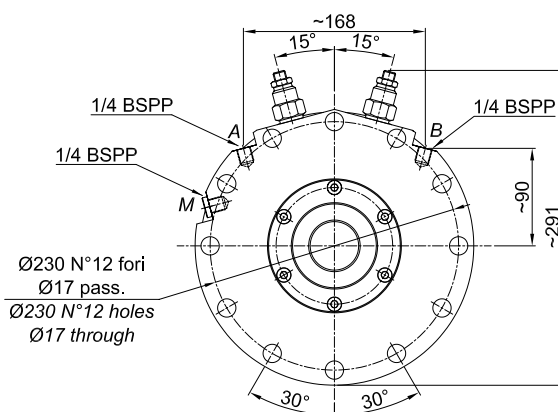

Valvola Overcenter Doppia
Double Overcenter Valve

P in A / C1 = Rot. R1 P in B / C2 = Rot. R2

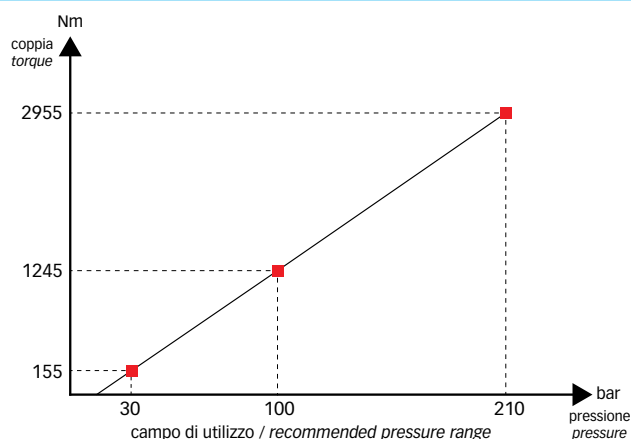

rotation	standard 270°
displacement	1086 cm ³
maximum drive torque at 210 bar	2955 Nm
maximum holding torque at 210 bar	4550 Nm
maximum pressure	210 bar
test pressure	320 bar
maximum thrust capacity	70000 N
maximum radial capacity	70000 N
max moment capacity straddle mounting	-
max moment capacity cantilever mounting	26000 Nm
weight	78 kg
seals	PTFE- NBR - Polyurethane
working temperature	from -20°C to +80°C
overcenter valve	see specific datasheet

For more technical details please visit our site www.movecosrl.com
 Moveco can modify the technical details without notice.

ARC 130 - RC.39/...

ATTUATORE ROTANTE
ROTARY ACTUATOR

H. MOVECO
ROTARY ACTUATORS
HYDRAULIC COMPONENTS



APPLICAZIONI PIU' COMUNI

Rotazione gruette girevoli e telescopiche o passerelle multifunzionali che comprendono anche la funzione di gruette; attuatore adatto a supportare momento ribaltante a sbalzo; applicazione più comune ad asse verticale.



STANDARD APPLICATIONS

This actuator is suitable to support a bending moment straddle mounting; mostly used on vertical axle for the rotation of slewing cranes and telescopic cranes, as well as multifunctional gangways used also for the crane function.





angolo di rotazione	standard 270°
cilindrata	1448 cm ³
coppia attiva massima a 210 bar	3900 Nm
coppia passiva massima a 210 bar	6000 Nm
pressione massima	210 bar
pressione di collaudo	320 bar
carico assiale massimo	70000 N
carico radiale massimo	70000 N
momento ribaltante massimo con attacco a forcella	-
momento ribaltante massimo con attacco a sbalzo	26000 Nm
peso	78 kg
materiale guarnizioni	PTFE- NBR - Poliuretano
temperatura	da -20°C a +80°C
valvola overcenter	vedi scheda relativa

Per maggiori dettagli tecnici consultate il nostro sito www.movecosrl.com
 Moveco si riserva la possibilità di apportare modifiche senza preavviso.

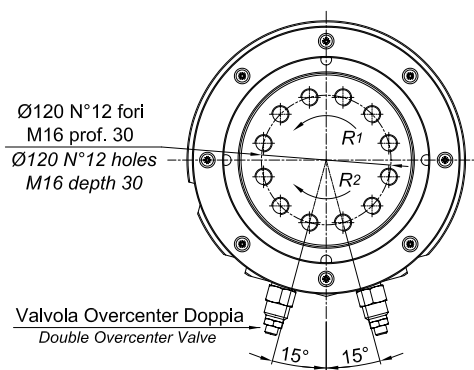
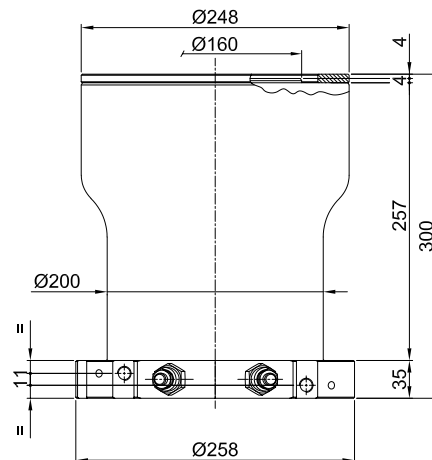
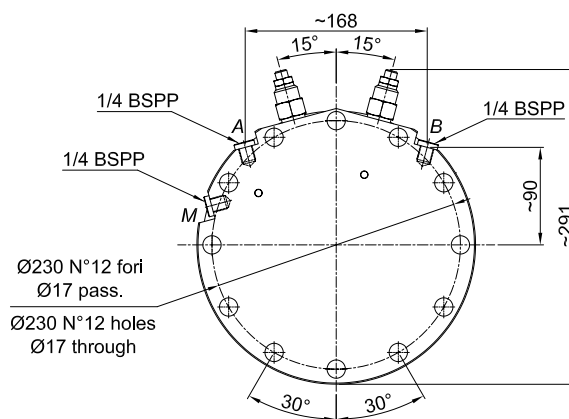

P in A / C1 = Rot. R1 P in B / C2 = Rot. R2

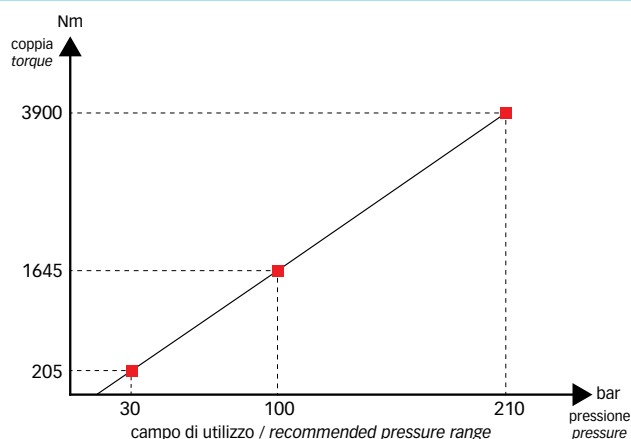

rotation	standard 270°
displacement	1448 cm ³
maximum drive torque at 210 bar	3900 Nm
maximum holding torque at 210 bar	6000 Nm
maximum pressure	210 bar
test pressure	320 bar
maximum thrust capacity	70000 N
maximum radial capacity	70000 N
max moment capacity straddle mounting	-
max moment capacity cantilever mounting	26000 Nm
weight	78 kg
seals	PTFE- NBR - Polyurethane
working temperature	from -20°C to +80°C
overcenter valve	see specific datasheet

For more technical details please visit our site www.movecosrl.com
 Moveco can modify the technical details without notice.

ARC 165 - RC.43/...

ATTUATORE ROTANTE
ROTARY ACTUATOR

H MOVECO
ROTARY ACTUATORS
HYDRAULIC COMPONENTS



APPLICAZIONI PIU' COMUNI

Rotazione gruette girevoli e telescopiche o passerelle multifunzionali che comprendono anche la funzione di gruette; attuatore adatto a supportare momento ribaltante a sbalzo; applicazione più comune ad asse verticale.



STANDARD APPLICATIONS

This actuator is suitable to support a bending moment straddle mounting; mostly used on vertical axle for the rotation of slewing cranes and telescopic cranes, as well as multifunctional gangways used also for the crane function.

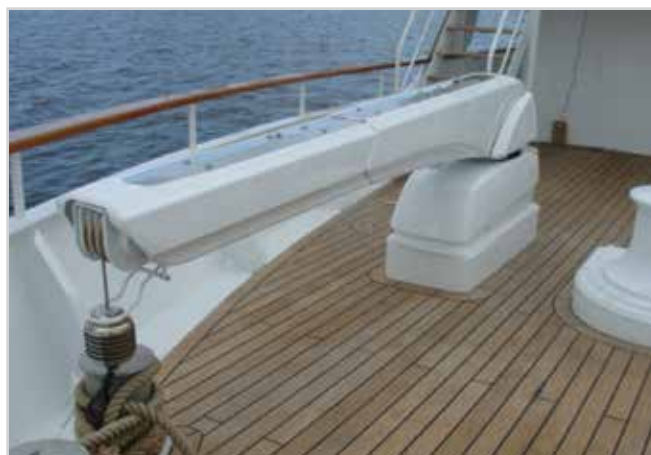



angolo di rotazione	standard 270° a richiesta: 360°
cilindrata	2392 cm ³ (3206 cm ³)
coppia attiva massima a 210 bar	6880 Nm
coppia passiva massima a 210 bar	10600 Nm
pressione massima	210 bar
pressione di collaudo	320 bar
carico assiale massimo	100000 N
carico radiale massimo	100000 N
momento ribaltante massimo con attacco a forcilla	-
momento ribaltante massimo con attacco a sbalzo	40000 Nm
peso	132 kg (160 kg)
materiale guarnizioni	PTFE- NBR - Poliuretano
temperatura	da -20°C a +80°C
valvola overcenter	vedi scheda relativa

I dati si riferiscono alla versione con 270° di rotazione; tra parentesi sono indicati i valori per il 360°

Per maggiori dettagli tecnici consultate il nostro sito www.movecosrl.com
 Moveco si riserva la possibilità di apportare modifiche senza preavviso.

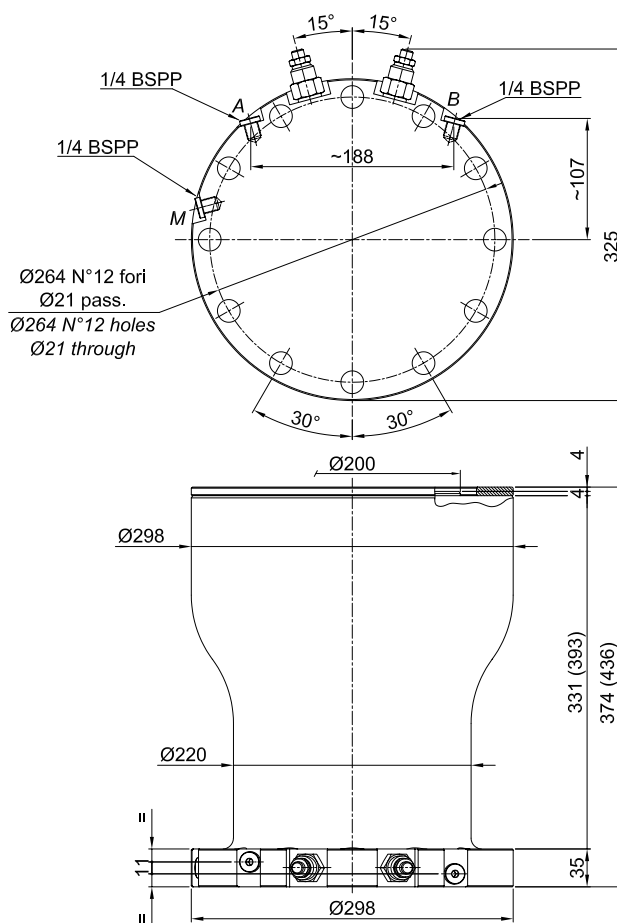

rotation	standard 270° special 360°
displacement	2392 cm ³ (3206 cm ³)
maximum drive torque at 210 bar	6880 Nm
maximum holding torque at 210 bar	10600 Nm
maximum pressure	210 bar
test pressure	320 bar
maximum thrust capacity	100000 N
maximum radial capacity	100000 N
max moment capacity straddle mounting	-
max moment capacity cantilever mounting	40000 Nm
weight	132 kg (160 kg)
seals	PTFE- NBR - Polyurethane
working temperature	from -20°C to +80°C
overcenter valve	see specific datasheet

Data refer to the version with 270° rotation; the values in brackets are for model 360°

For more technical details please visit our site www.movecosrl.com
 Moveco can modify the technical details without notice.

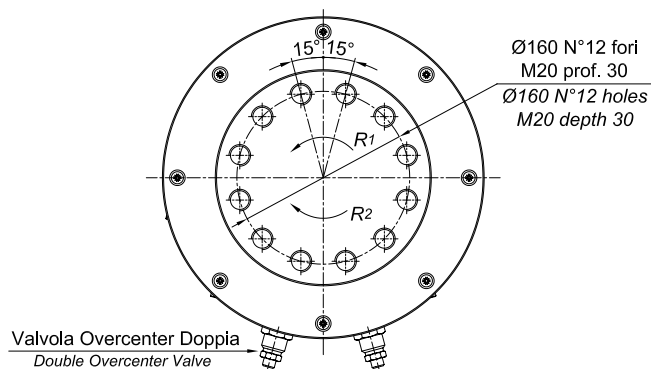

P in A / C1 = Rot. R1 P in B / C2 = Rot. R2

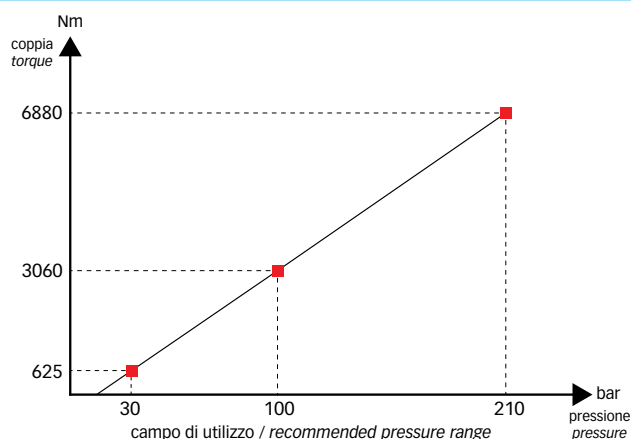

ARC 280 - RC.51/...

ATTUATORE ROTANTE
ROTARY ACTUATOR

H. MOVECO
ROTARY ACTUATORS
HYDRAULIC COMPONENTS

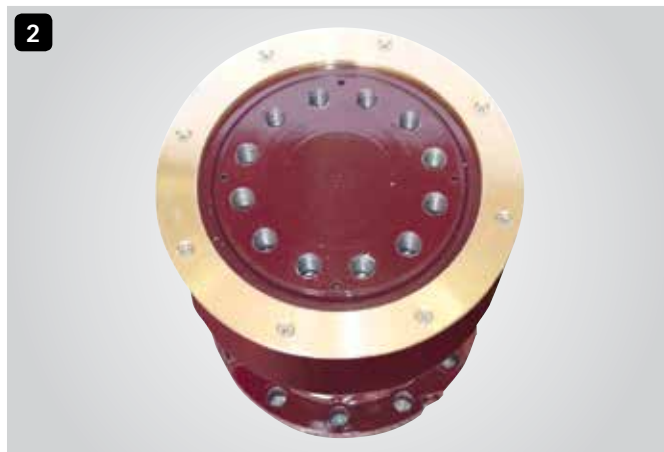

APPLICAZIONI PIU' COMUNI

Rotazione gruette girevoli e telescopiche o passerelle multifunzionali che comprendono anche la funzione di gruette; attuatore adatto a supportare momento ribaltante a sbalzo; applicazione più comune ad asse verticale.



STANDARD APPLICATIONS

This actuator is suitable to support a bending moment straddle mounting; mostly used on vertical axle for the rotation of slewing cranes and telescopic cranes, as well as multifunctional gangways used also for the crane function.





angolo di rotazione	standard 180°
cilindrata	117 cm ³
coppia attiva massima a 210 bar	505 Nm
coppia passiva massima a 210 bar	730 Nm
pressione massima	210 bar
pressione di collaudo	320 bar
carico assiale massimo	5000 N
carico radiale massimo	14000 N
momento ribaltante massimo con attacco a forcella	2800 Nm
momento ribaltante massimo con attacco a sbalzo	1400 Nm
peso	12 kg
materiale guarnizioni	PTFE- NBR - Poliuretano
temperatura	da -20°C a +80°C
valvola overcenter	vedi scheda relativa

Per maggiori dettagli tecnici consultate il nostro sito www.movecosrl.com
 Moveco si riserva la possibilità di apportare modifiche senza preavviso.

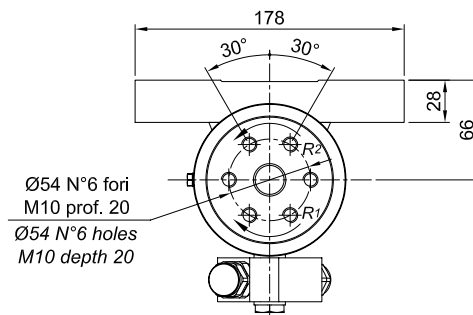
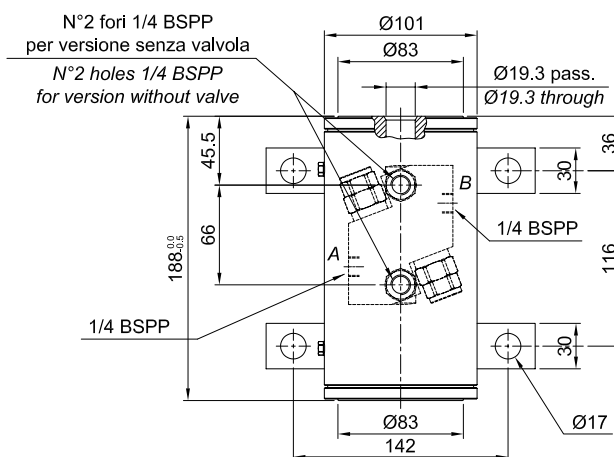
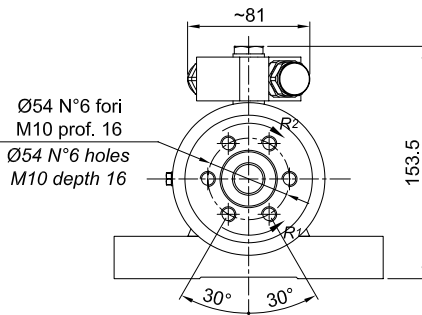

P in A / C1 = Rot. R1 P in B / C2 = Rot. R2



rotation	standard 180°
displacement	117 cm ³
maximum drive torque at 210 bar	505 Nm
maximum holding torque at 210 bar	730 Nm
maximum pressure	210 bar
test pressure	320 bar
maximum thrust capacity	5000 N
maximum radial capacity	14000 N
max moment capacity straddle mounting	2800 Nm
max moment capacity cantilever mounting	1400 Nm
weight	12 kg
seals	PTFE- NBR - Polyurethane
working temperature	from -20°C to +80°C
overcenter valve	see specific datasheet

For more technical details please visit our site www.movecosrl.com
 Moveco can modify the technical details without notice.

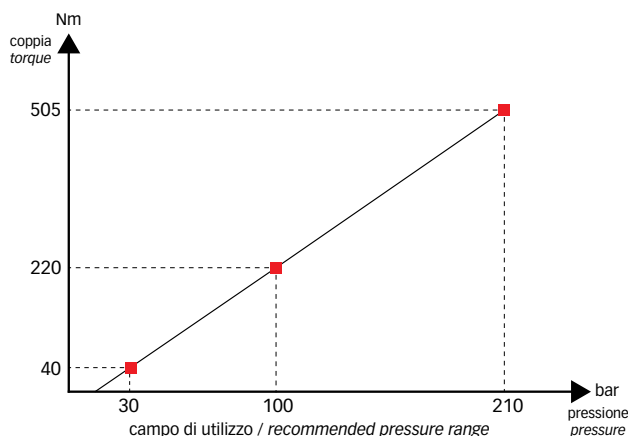

ARP 25 - RP.17/...

ATTUATORE ROTANTE
ROTARY ACTUATOR

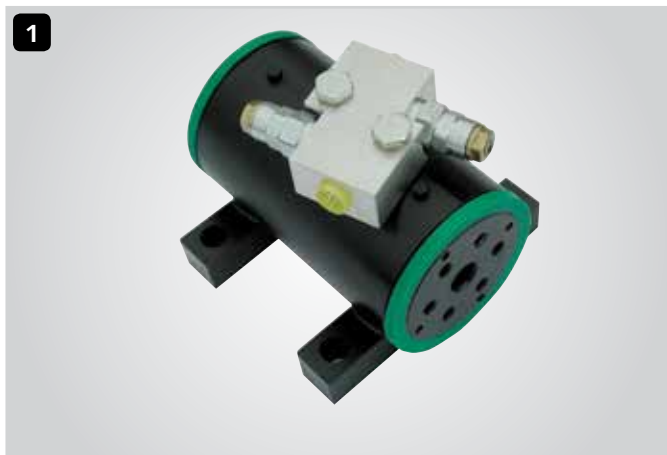

APPLICAZIONI PIU' COMUNI

Rotazione del cesto e del braccio jib su piattaforme aeree; attuatore adatto a supportare momento ribaltante a forcella od a sbalzo; applicazione più comune ad asse verticale.



STANDARD APPLICATIONS

This actuator can support a bending moment, cantilever or straddle mounting, normally used on vertical axle for the rotation of basket and jib on aerial platforms.



ARP 40 - RP.24/...

ATTUATORE ROTANTE
ROTARY ACTUATOR

H. MOVECO
ROTARY ACTUATORS
HYDRAULIC COMPONENTS

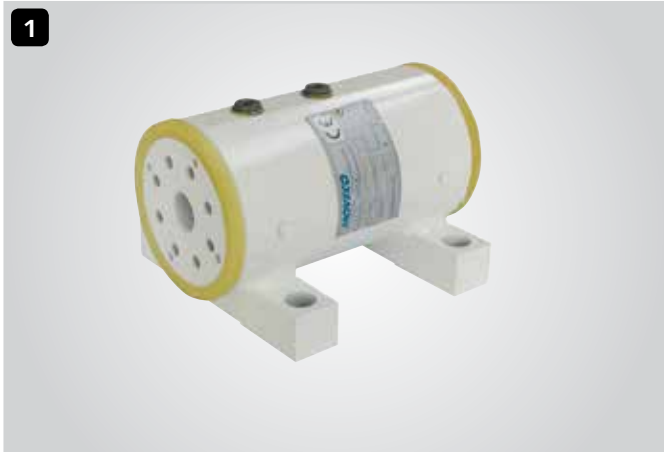

APPLICAZIONI PIU' COMUNI

Rotazione del cesto e del braccio jib su piattaforme aeree; attuatore adatto a supportare momento ribaltante a forcella od a sbalzo; applicazione più comune ad asse verticale.



STANDARD APPLICATIONS

This actuator can support a bending moment, cantilever or straddle mounting, normally used on vertical axle for the rotation of basket and jib on aerial platforms.





angolo di rotazione	standard 180°
cilindrata	222 cm ³
coppia attiva massima a 210 bar	960 Nm
coppia passiva massima a 210 bar	1380 Nm
pressione massima	210 bar
pressione di collaudo	320 bar
carico assiale massimo	7000 N
carico radiale massimo	28000 N
momento ribaltante massimo con attacco a forcella	9000 Nm
momento ribaltante massimo con attacco a sbalzo	3000 Nm
peso	22 kg
materiale guarnizioni	PTFE- NBR - Poliuretano
temperatura	da -20°C a +80°C
valvola overcenter	vedi scheda relativa

Per maggiori dettagli tecnici consultate il nostro sito www.movecosrl.com
 Moveco si riserva la possibilità di apportare modifiche senza preavviso.

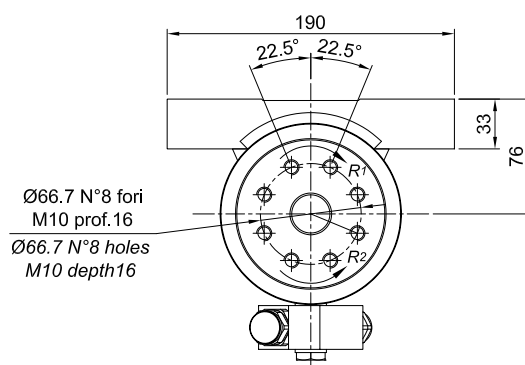
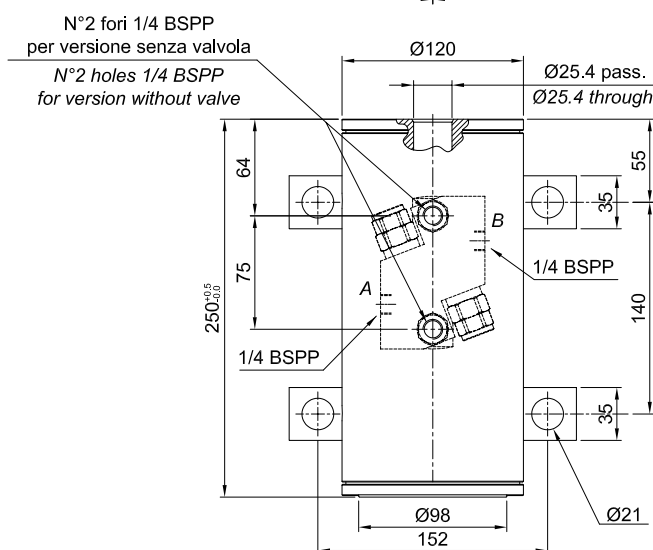
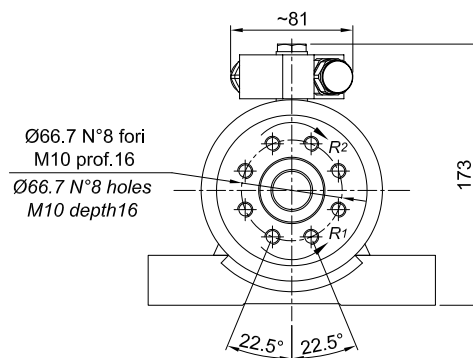

P in A / C1 = Rot. R1 P in B / C2 = Rot. R2



rotation	standard 180°
displacement	222 cm ³
maximum drive torque at 210 bar	960 Nm
maximum holding torque at 210 bar	1380 Nm
maximum pressure	210 bar
test pressure	320 bar
maximum thrust capacity	7000 N
maximum radial capacity	28000 N
max moment capacity straddle mounting	9000 Nm
max moment capacity cantilever mounting	3000 Nm
weight	22 kg
seals	PTFE- NBR - Polyurethane
working temperature	from -20°C to +80°C
overcenter valve	see specific datasheet

For more technical details please visit our site www.movecosrl.com
 Moveco can modify the technical details without notice.

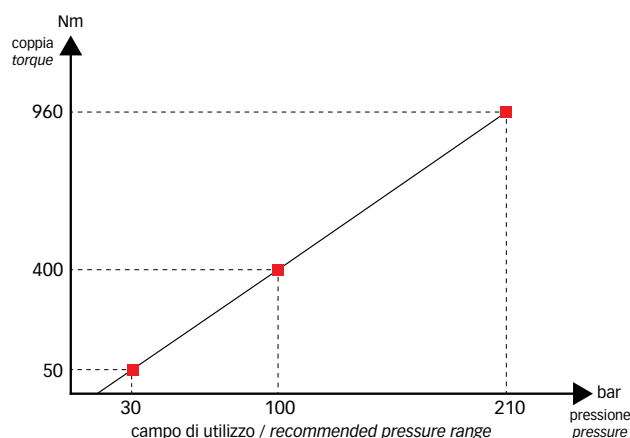

ARP 40R - RP.25/...

ATTUATORE ROTANTE
ROTARY ACTUATOR

H. MOVECO
ROTARY ACTUATORS
HYDRAULIC COMPONENTS



APPLICAZIONI PIU' COMUNI

Rotazione del cesto e del braccio jib su piattaforme aeree; attuatore adatto a supportare momento ribaltante a forcella od a sbalzo; applicazione più comune ad asse verticale.



STANDARD APPLICATIONS

This actuator can support a bending moment, cantilever or straddle mounting, normally used on vertical axle for the rotation of basket and jib on aerial platforms.





angolo di rotazione	standard 180° a richiesta: 270°
cilindrata	421 cm ³ (631 cm ³)
coppia attiva massima a 210 bar	1865 Nm
coppia passiva massima a 210 bar	2670 Nm
pressione massima	210 bar
pressione di collaudo	320 bar
carico assiale massimo	8000 N
carico radiale massimo	30000 N
momento ribaltante massimo con attacco a forcella	12000 Nm
momento ribaltante massimo con attacco a sbalzo	5400 Nm
peso	32 kg (40 kg)
materiale guarnizioni	PTFE- NBR - Poliuretano
temperatura	da -20°C a +80°C
valvola overcenter	vedi scheda relativa

I dati si riferiscono alla versione con 180° di rotazione; tra parentesi sono indicati i valori per il 270°

Per maggiori dettagli tecnici consultate il nostro sito www.movecosrl.com
 Moveco si riserva la possibilità di apportare modifiche senza preavviso.

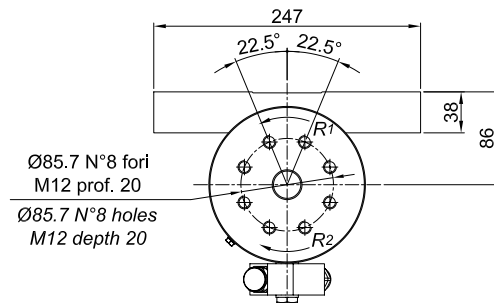
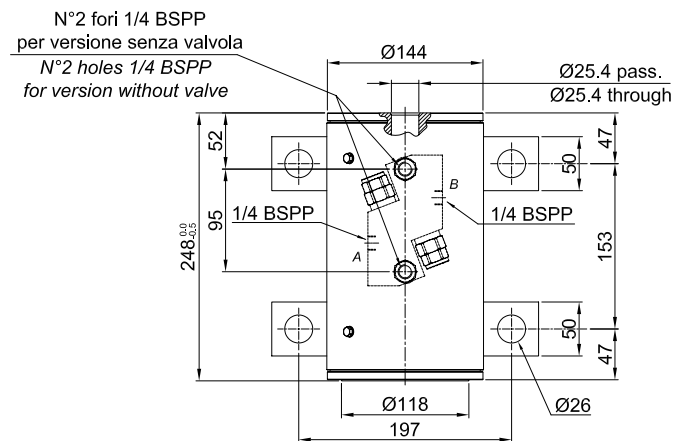
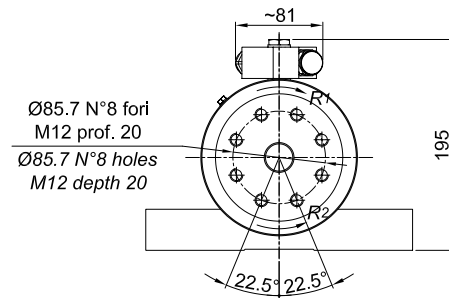

P in A / C1 = Rot. R1 P in B / C2 = Rot. R2



rotation	standard 180° special 270°
displacement	421 cm ³ (631 cm ³)
maximum drive torque at 210 bar	1865 Nm
maximum holding torque at 210 bar	2670 Nm
maximum pressure	210 bar
test pressure	320 bar
maximum thrust capacity	8000 N
maximum radial capacity	30000 N
max moment capacity straddle mounting	12000 Nm
max moment capacity cantilever mounting	5400 Nm
weight	32 kg (40 kg)
seals	PTFE- NBR - Polyurethane
working temperature	from -20°C to +80°C
overcenter valve	see specific datasheet

Data refer to the version with 180° rotation; the values in brackets are for model 270°

For more technical details please visit our site www.movecosrl.com
 Moveco can modify the technical details without notice.

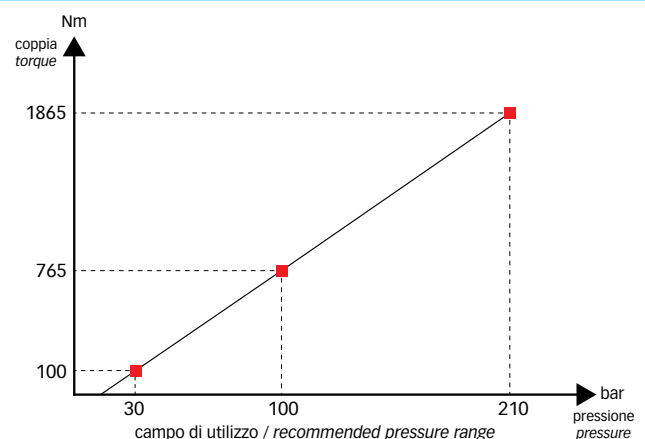

ARP 80 - RP.33/...

ATTUATORE ROTANTE
ROTARY ACTUATOR



APPLICAZIONI PIU' COMUNI

Rotazione del cesto e del braccio jib su piattaforme aeree; attuatore adatto a supportare momento ribaltante a forcella od a sbalzo; applicazione più comune ad asse verticale.



STANDARD APPLICATIONS

This actuator can support a bending moment, cantilever or straddle mounting, normally used on vertical axle for the rotation of basket and jib on aerial platforms.





angolo di rotazione	standard 180° a richiesta: 270°
cilindrata	854 cm ³ (1282 cm ³)
coppia attiva massima a 210 bar	4160 Nm
coppia passiva massima a 210 bar	5800 Nm
pressione massima	210 bar
pressione di collaudo	320 bar
carico assiale massimo	40000 N
carico radiale massimo	40000 N
momento ribaltante massimo con attacco a forcilla	18000 Nm
momento ribaltante massimo con attacco a sbalzo	6500 Nm
peso	45 kg (52 kg)
materiale guarnizioni	PTFE- NBR - Poliuretano
temperatura	da -20°C a +80°C
valvola overcenter	vedi scheda relativa

I dati si riferiscono alla versione con 180° di rotazione; tra parentesi sono indicati i valori per il 270°

Per maggiori dettagli tecnici consultate il nostro sito www.movecosrl.com
 Moveco si riserva la possibilità di apportare modifiche senza preavviso.

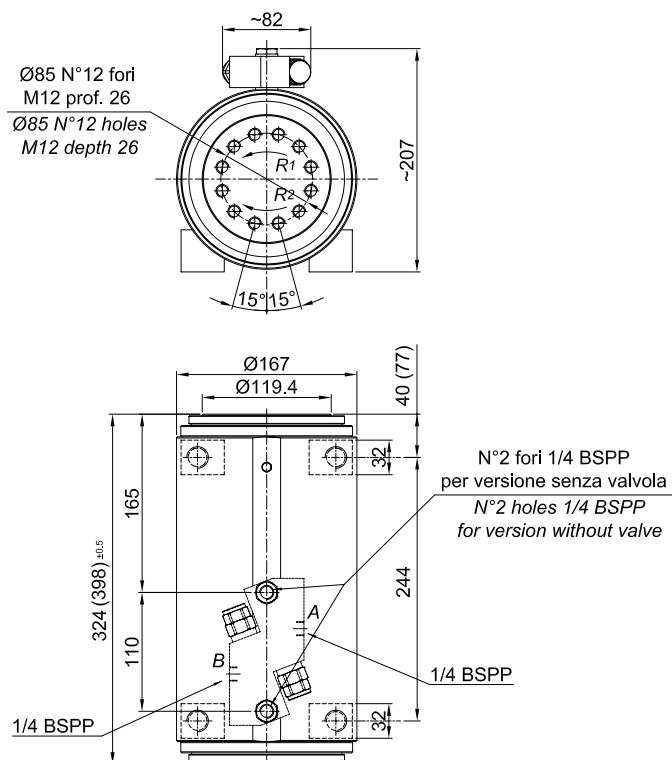

rotation	standard 180° special 270°
displacement	854 cm ³ (1282 cm ³)
maximum drive torque at 210 bar	4160 Nm
maximum holding torque at 210 bar	5800 Nm
maximum pressure	210 bar
test pressure	320 bar
maximum thrust capacity	40000 N
maximum radial capacity	40000 N
max moment capacity straddle mounting	18000 Nm
max moment capacity cantilever mounting	6500 Nm
weight	45 kg (52 kg)
seals	PTFE- NBR - Polyurethane
working temperature	from -20°C to +80°C
overcenter valve	see specific datasheet

Data refer to the version with 180° rotation; the values in brackets are for model 270°

For more technical details please visit our site www.movecosrl.com
 Moveco can modify the technical details without notice.

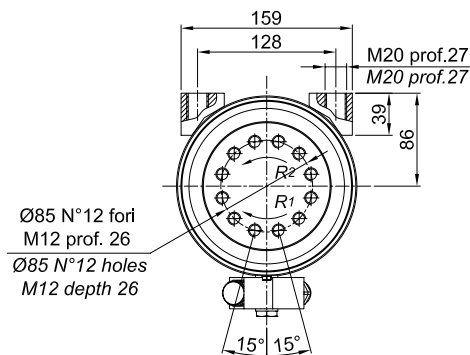

P in A / C1 = Rot. R1 P in B / C2 = Rot. R2

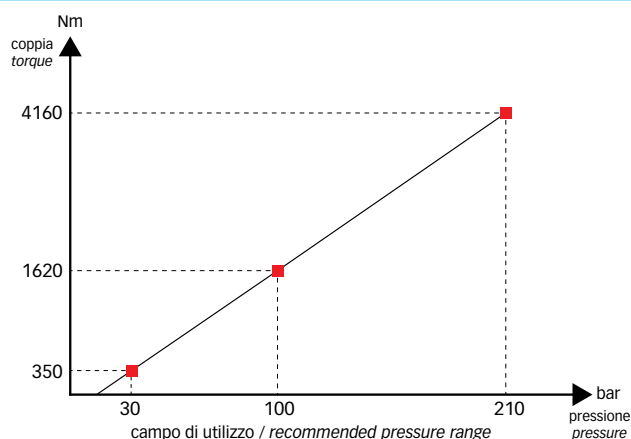

ARP 200 - RP.44/...

ATTUATORE ROTANTE
ROTARY ACTUATOR

H. MOVECO
ROTARY ACTUATORS
HYDRAULIC COMPONENTS

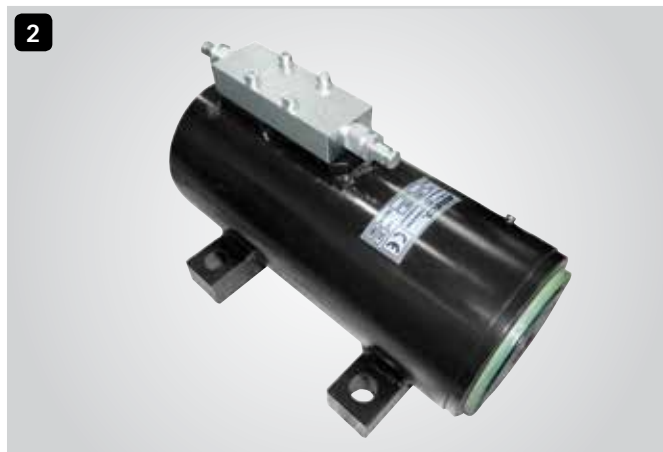

APPLICAZIONI PIU' COMUNI

Livellamento del cesto e del braccio jib su piattaforme aeree;
attuatore adatto a supportare momento ribaltante a forcella od a sbalzo; applicazione più comune ad asse orizzontale.



STANDARD APPLICATIONS

This actuator is suitable to support a bending moment, cantilever and straddle mounting, normally used on horizontal axle suitable for levelling of basket and jib on aerial platforms.





angolo di rotazione	standard 180°
cilindrata	1270 cm ³
coppia attiva massima a 210 bar	5870 Nm
coppia passiva massima a 210 bar	8400 Nm
pressione massima	210 bar
pressione di collaudo	320 bar
carico assiale massimo	40000 N
carico radiale massimo	40000 N
momento ribaltante massimo con attacco a forcella	18000 Nm
momento ribaltante massimo con attacco a sbalzo	6500 Nm
peso	49 kg
materiale guarnizioni	PTFE- NBR - Poliuretano
temperatura	da -20°C a +80°C
valvola overcenter	vedi scheda relativa

Per maggiori dettagli tecnici consultate il nostro sito www.movecosrl.com
 Moveco si riserva la possibilità di apportare modifiche senza preavviso.



rotation	standard 180°
displacement	1270 cm ³
maximum drive torque at 210 bar	5870 Nm
maximum holding torque at 210 bar	8400 Nm
maximum pressure	210 bar
test pressure	320 bar
maximum thrust capacity	40000 N
maximum radial capacity	40000 N
max moment capacity straddle mounting	18000 Nm
max moment capacity cantilever mounting	6500 Nm
weight	49 kg
seals	PTFE- NBR - Polyurethane
working temperature	from -20°C to +80°C
overcenter valve	see specific datasheet

For more technical details please visit our site www.movecosrl.com
 Moveco can modify the technical details without notice.

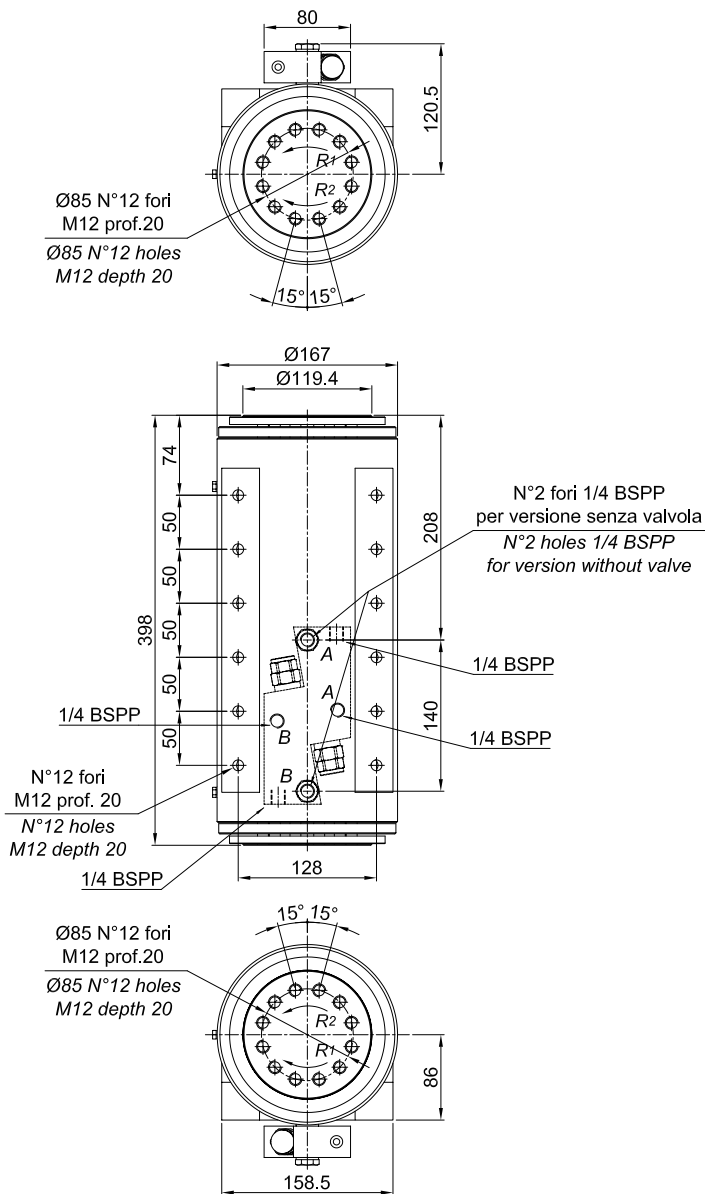

P in A / C1 = Rot. R1 P in B / C2 = Rot. R2

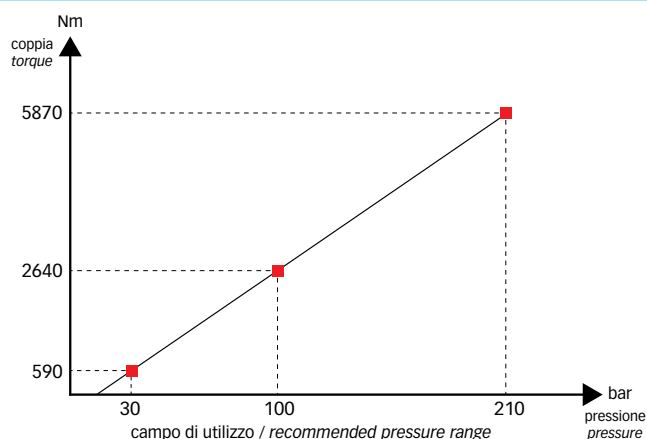

ARP 265 - RP.49/...

ATTUATORE ROTANTE
ROTARY ACTUATOR

H. MOVECO
ROTARY ACTUATORS
HYDRAULIC COMPONENTS



APPLICAZIONI PIU' COMUNI

Livellamento del cesto e del braccio jib su piattaforme aeree;
attuatore adatto a supportare momento ribaltante a forcella od a sbalzo; applicazione più comune ad asse orizzontale.



STANDARD APPLICATIONS

This actuator is suitable to support a bending moment, cantilever and straddle mounting, normally used on horizontal axle suitable for levelling of basket and jib on aerial platforms.





angolo di rotazione	standard 270°
cilindrata	2441 cm ³
coppia attiva massima a 210 bar	7620 Nm
coppia passiva massima a 210 bar	11000 Nm
pressione massima	210 bar
pressione di collaudo	320 bar
carico assiale massimo	65000 N
carico radiale massimo	65000 N
momento ribaltante massimo con attacco a forcella	32000 Nm
momento ribaltante massimo con attacco a sbalzo	9000 Nm
peso	116 kg
materiale guarnizioni	PTFE- NBR - Poliuretano
temperatura	da -20°C a +80°C
valvola overcenter	vedi scheda relativa

Per maggiori dettagli tecnici consultate il nostro sito www.movecosrl.com
 Moveco si riserva la possibilità di apportare modifiche senza preavviso.

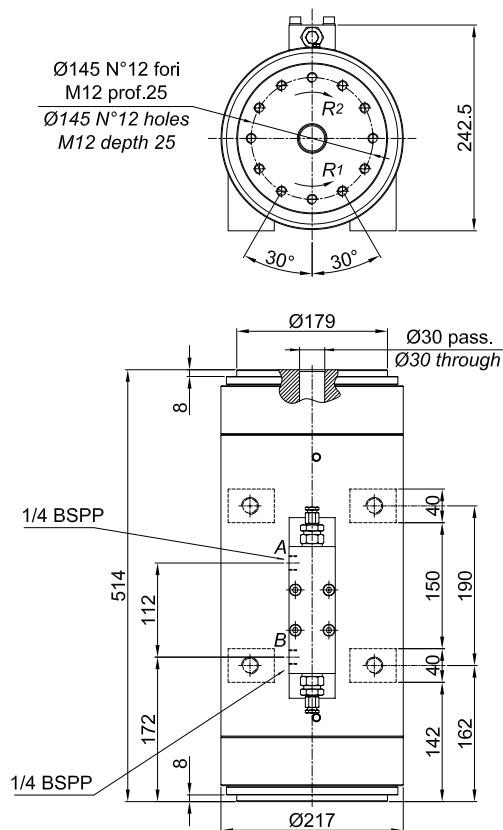

rotation	standard 270°
displacement	2441 cm ³
maximum drive torque at 210 bar	7620 Nm
maximum holding torque at 210 bar	11000 Nm
maximum pressure	210 bar
test pressure	320 bar
maximum thrust capacity	65000 N
maximum radial capacity	65000 N
max moment capacity straddle mounting	32000 Nm
max moment capacity cantilever mounting	9000 Nm
weight	116 kg
seals	PTFE- NBR - Polyurethane
working temperature	from -20°C to +80°C
overcenter valve	see specific datasheet

For more technical details please visit our site www.movecosrl.com
 Moveco can modify the technical details without notice.

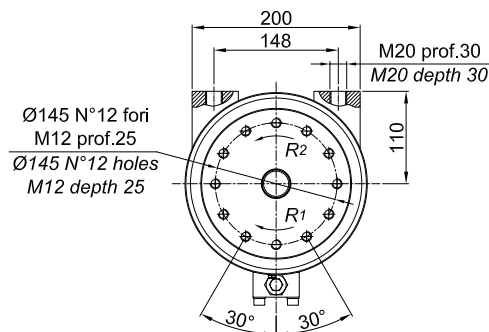

P in A / C1 = Rot. R1 P in B / C2 = Rot. R2

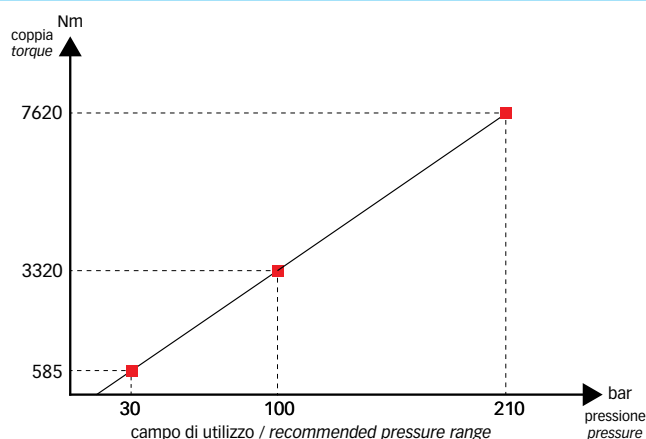

ARP 350 - RP.52/...

ATTUATORE ROTANTE
ROTARY ACTUATOR

H. MOVECO
ROTARY ACTUATORS
HYDRAULIC COMPONENTS



APPLICAZIONI PIU' COMUNI

Livellamento del cesto e del braccio jib su piattaforme aeree;
attuatore adatto a supportare momento ribaltante a forcella od a sbalzo; applicazione più comune ad asse orizzontale.



STANDARD APPLICATIONS

This actuator is suitable to support a bending moment, cantilever and straddle mounting, normally used on horizontal axle suitable for levelling basket and jib on aerial platforms.



ARP 510 - RP.57/...

ATTUATORE ROTANTE
ROTARY ACTUATOR

H. MOVECO
ROTARY ACTUATORS
HYDRAULIC COMPONENTS



APPLICAZIONI PIU' COMUNI

Livellamento del cesto e del braccio jib su piattaforme aeree;
attuatore adatto a supportare momento ribaltante a forcella od a sbalzo; applicazione più comune ad asse orizzontale.



STANDARD APPLICATIONS

This actuator is suitable to support a bending moment, cantilever and straddle mounting, normally used on horizontal axle suitable for levelling basket and jib on aerial platforms.



ARP 550 - RP.58/...

ATTUATORE ROTANTE
ROTARY ACTUATOR

H MOVECO
ROTARY ACTUATORS
HYDRAULIC COMPONENTS



APPLICAZIONI PIU' COMUNI

Livellamento del cesto e del braccio jib su piattaforme aeree;
attuatore adatto a supportare momento ribaltante a forcella od a sbalzo; applicazione più comune ad asse orizzontale.



STANDARD APPLICATIONS

This actuator is suitable to support a bending moment, cantilever and straddle mounting, normally used on horizontal axle suitable for levelling basket and jib on aerial platforms.





angolo di rotazione	standard 180° a richiesta: 360°
cilindrata	461 cm ³ (921 cm ³)
coppia attiva massima a 210 bar	2020 Nm
coppia passiva massima a 210 bar	2890 Nm
pressione massima	210 bar
pressione di collaudo	320 bar
carico assiale massimo	14000 N
carico radiale massimo	18000 N
momento ribaltante massimo con attacco a forcella	14000 Nm
momento ribaltante massimo con attacco a sbalzo	5500 Nm
peso	35 kg (43 kg)
materiale guarnizioni	PTFE- NBR - Poliuretano
temperatura	da -20°C a +80°C
valvola overcenter	vedi scheda relativa

I dati si riferiscono alla versione con 180° di rotazione; tra parentesi sono indicati i valori per il 360°

Per maggiori dettagli tecnici consultate il nostro sito www.movecosrl.com
 Moveco si riserva la possibilità di apportare modifiche senza preavviso.

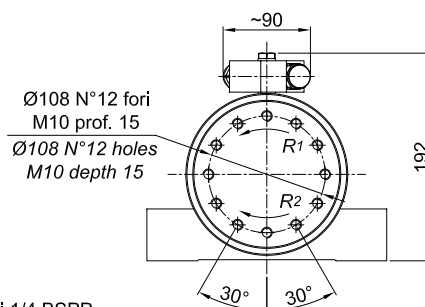

N°2 fori 1/4 BSPP
per versione senza valvola
N°2 holes 1/4 BSPP
for version without valve

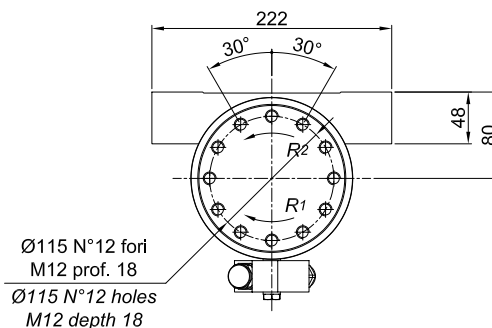
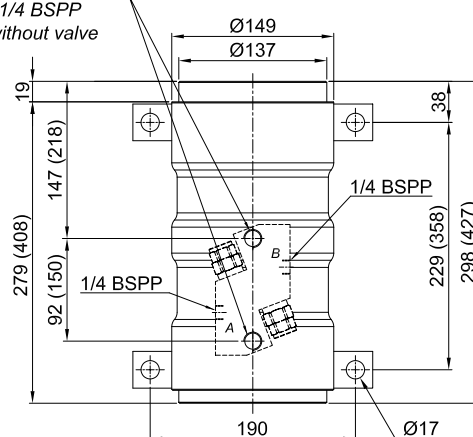

P in A / C1 = Rot. R1 P in B / C2 = Rot. R2



rotation	standard 180° special 360°
displacement	461 cm ³ (921 cm ³)
maximum drive torque at 210 bar	2020 Nm
maximum holding torque at 210 bar	2890 Nm
maximum pressure	210 bar
test pressure	320 bar
maximum thrust capacity	14000 N
maximum radial capacity	18000 N
max moment capacity straddle mounting	14000 Nm
max moment capacity cantilever mounting	5500 Nm
weight	35 kg (43 kg)
seals	PTFE- NBR - Polyurethane
working temperature	from -20°C to +80°C
overcenter valve	see specific datasheet

Data refer to the version with 180° rotation; the values in brackets are for model 360°

For more technical details please visit our site www.movecosrl.com
 Moveco can modify the technical details without notice.

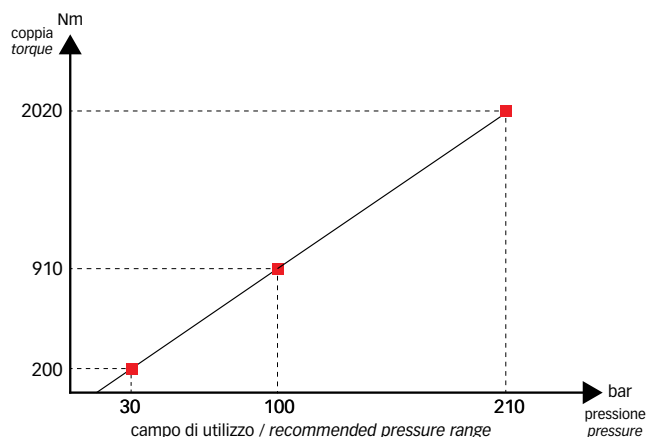

ARR 95 - RR.34/...

ATTUATORE ROTANTE
ROTARY ACTUATOR



1

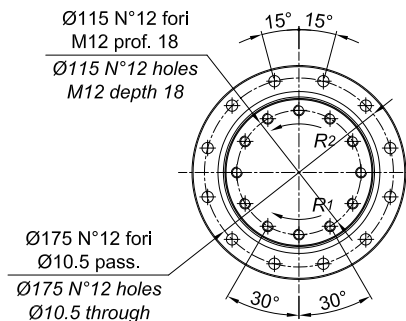

2

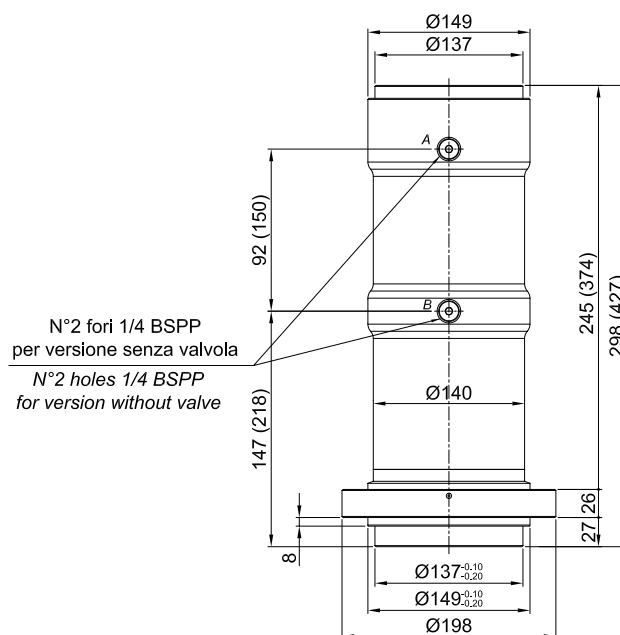

APPLICAZIONI PIU' COMUNI

Movimentazione delle teste perforanti o del braccio porta utensili su macchine da miniera o per impieghi gravosi; attuatore adatto a supportare momento ribaltante a forcella od a sbalzo; applicazione più comune ad asse orizzontale.



STANDARD APPLICATIONS

Actuator suitable to support a bending moment, cantilever or straddle mounting, normally used on horizontal axle for moving of drilling heads or tool-holder arm on mining drilling machines or for heavy duty applications.





angolo di rotazione	standard 180°
cilindrata	716 cm ³
coppia attiva massima a 210 bar	3100 Nm
coppia passiva massima a 210 bar	4430 Nm
pressione massima	210 bar
pressione di collaudo	320 bar
carico assiale massimo	18000 N
carico radiale massimo	25000 N
momento ribaltante massimo con attacco a forcella	17500 Nm
momento ribaltante massimo con attacco a sbalzo	7500 Nm
peso	60 kg
materiale guarnizioni	PTFE- NBR - Poliuretano
temperatura	da -20°C a +80°C
valvola overcenter	vedi scheda relativa

Per maggiori dettagli tecnici consultate il nostro sito www.movecosrl.com
 Moveco si riserva la possibilità di apportare modifiche senza preavviso.

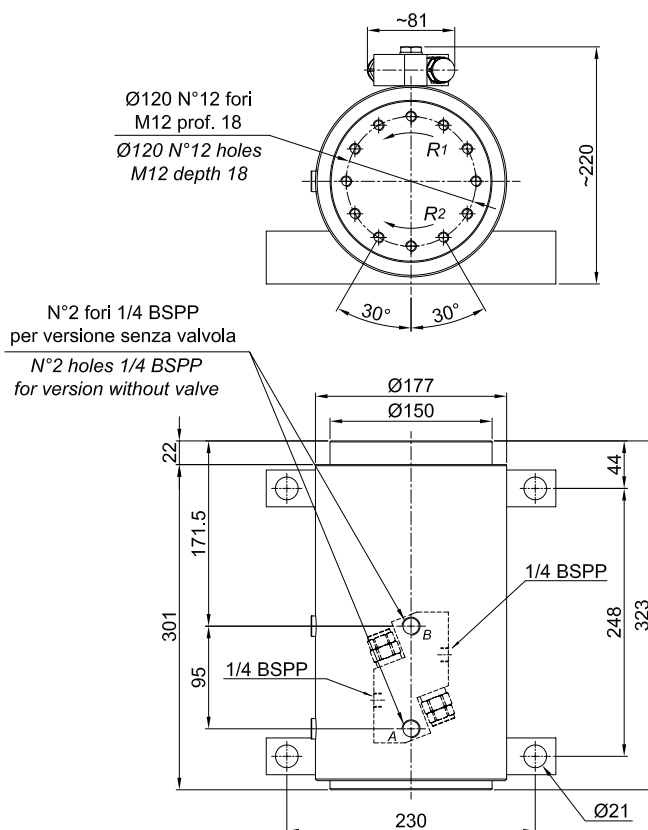

rotation	standard 180°
displacement	716 cm ³
maximum drive torque at 210 bar	3100 Nm
maximum holding torque at 210 bar	4430 Nm
maximum pressure	210 bar
test pressure	320 bar
maximum thrust capacity	18000 N
maximum radial capacity	25000 N
max moment capacity straddle mounting	17500 Nm
max moment capacity cantilever mounting	7500 Nm
weight	60 kg
seals	PTFE- NBR - Polyurethane
working temperature	from -20°C to +80°C
overcenter valve	see specific datasheet

For more technical details please visit our site www.movecosrl.com
 Moveco can modify the technical details without notice.

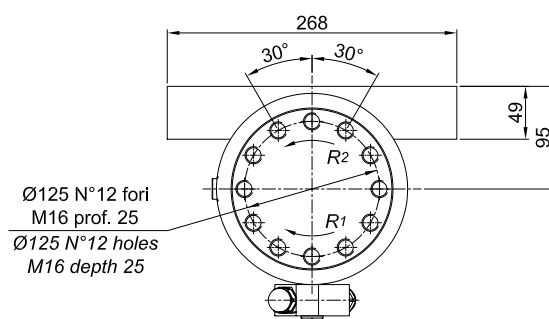

P in A / C1 = Rot. R1 P in B / C2 = Rot. R2

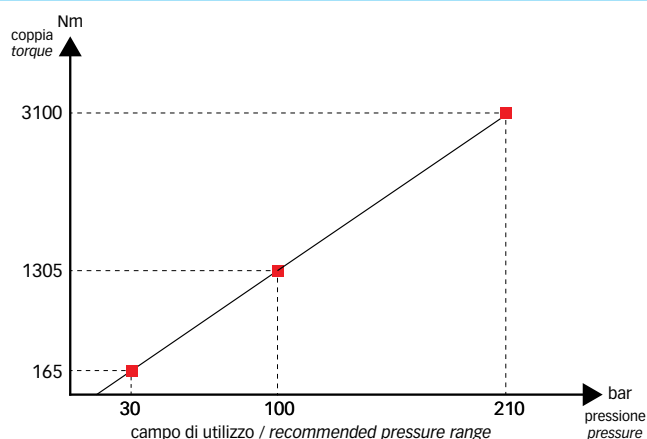

ARR 150 - RR.40/...

ATTUATORE ROTANTE
ROTARY ACTUATOR

H. MOVECO
ROTARY ACTUATORS
HYDRAULIC COMPONENTS

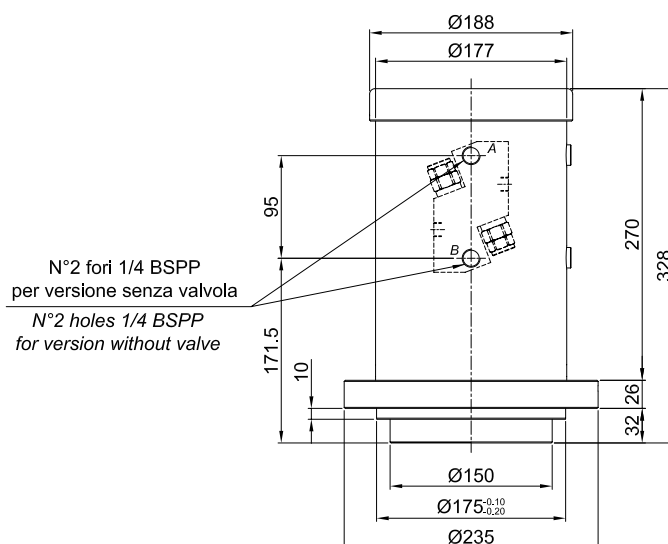
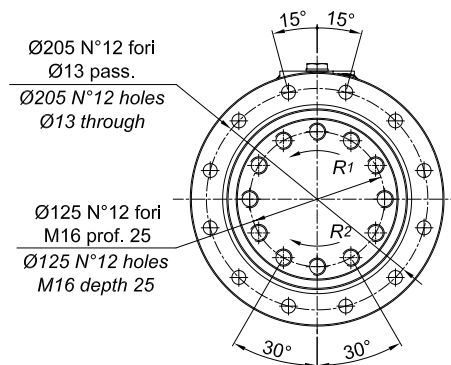

APPLICAZIONI PIU' COMUNI

Movimentazione delle teste perforanti o del braccio porta utensili su macchine da miniera o per impieghi gravosi; attuatore adatto a supportare momento ribaltante a forcella od a sbalzo; applicazione più comune ad asse orizzontale.



STANDARD APPLICATIONS

Actuator suitable to support a bending moment, cantilever or straddle mounting, normally used on horizontal axle for moving of drilling heads or tool-holder arm on mining drilling machines or for heavy duty applications.





angolo di rotazione	standard 180° a richiesta: 360°
cilindrata	1161 cm ³ (2323 cm ³)
coppia attiva massima a 210 bar	5100 Nm
coppia passiva massima a 210 bar	8100 Nm
pressione massima	210 bar
pressione di collaudo	320 bar
carico assiale massimo	30000 N
carico radiale massimo	36000 N
momento ribaltante massimo con attacco a forcina	31000 Nm
momento ribaltante massimo con attacco a sbalzo	12000 Nm
peso	85 kg (110 kg)
materiale guarnizioni	PTFE- NBR - Poliuretano
temperatura	da -20°C a +80°C
valvola overcenter	vedi scheda relativa

I dati si riferiscono alla versione con 180° di rotazione; tra parentesi sono indicati i valori per il 360°

Per maggiori dettagli tecnici consultate il nostro sito www.movecosrl.com
 Moveco si riserva la possibilità di apportare modifiche senza preavviso.

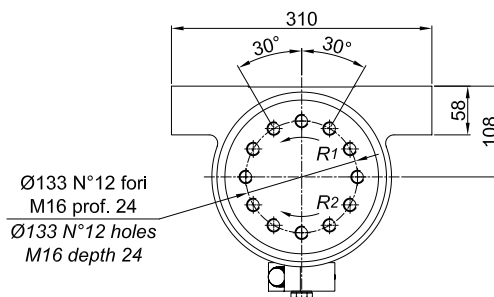
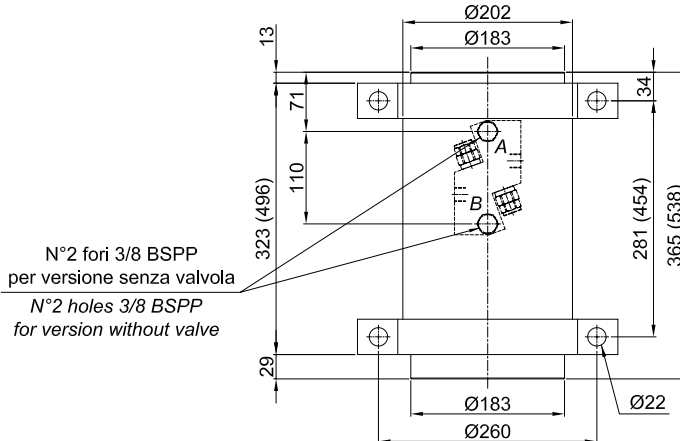
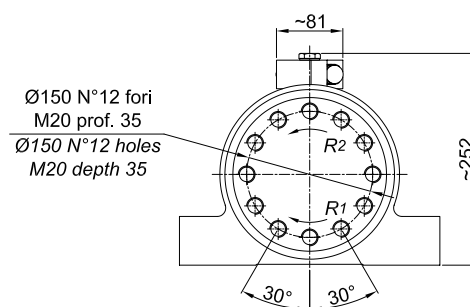

P in A / C1 = Rot. R1 P in B / C2 = Rot. R2

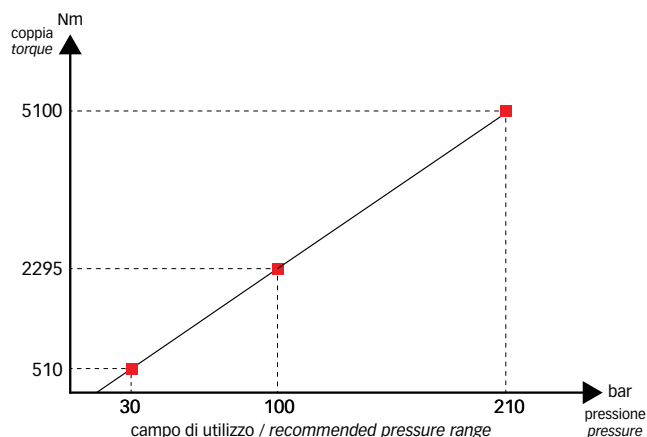

rotation	standard 180° special 360°
displacement	1161 cm ³ (2323 cm ³)
maximum drive torque at 210 bar	5100 Nm
maximum holding torque at 210 bar	8100 Nm
maximum pressure	210 bar
test pressure	320 bar
maximum thrust capacity	30000 N
maximum radial capacity	36000 N
max moment capacity straddle mounting	31000 Nm
max moment capacity cantilever mounting	12000 Nm
weight	85 kg (110 kg)
seals	PTFE- NBR - Polyurethane
working temperature	from -20°C to +80°C
overcenter valve	see specific datasheet

Data refer to the version with 180° rotation; the values in brackets are for model 360°

For more technical details please visit our site www.movecosrl.com
 Moveco can modify the technical details without notice.

ARR 240 - RR.46/...

ATTUATORE ROTANTE
ROTARY ACTUATOR

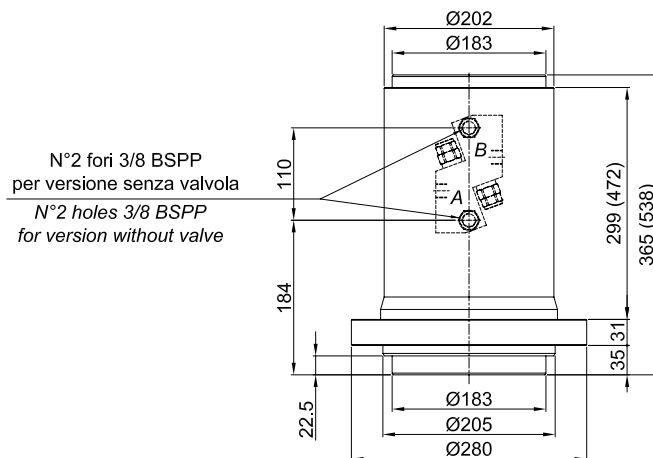
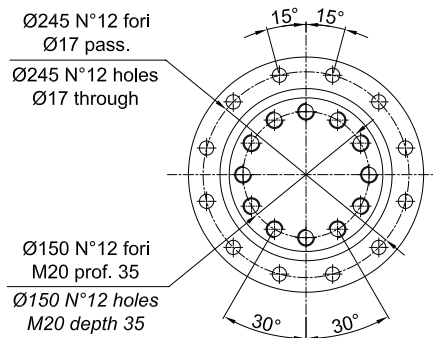

APPLICAZIONI PIU' COMUNI

Movimentazione delle teste perforanti o del braccio porta utensili su macchine da miniera o per impieghi gravosi; attuatore adatto a supportare momento ribaltante a forcella od a sbalzo; applicazione più comune ad asse orizzontale.



STANDARD APPLICATIONS

Actuator suitable to support a bending moment, cantilever or straddle mounting, normally used on horizontal axle for moving of drilling heads or tool-holder arm on mining drilling machines or for heavy duty applications.





angolo di rotazione	standard 180° a richiesta: 360°
cilindrata	1722 cm ³ (3444 cm ³)
coppia attiva massima a 210 bar	7600 Nm
coppia passiva massima a 210 bar	10900 Nm
pressione massima	210 bar
pressione di collaudo	320 bar
carico assiale massimo	65000 N
carico radiale massimo	65000 N
momento ribaltante massimo con attacco a forcilla	45000 Nm
momento ribaltante massimo con attacco a sbalzo	20000 Nm
peso	135 kg (170 kg)
materiale guarnizioni	PTFE- NBR - Poliuretano
temperatura	da -20°C a +80°C
valvola overcenter	vedi scheda relativa

I dati si riferiscono alla versione con 180° di rotazione; tra parentesi sono indicati i valori per il 360°

Per maggiori dettagli tecnici consultate il nostro sito www.movecosrl.com
 Moveco si riserva la possibilità di apportare modifiche senza preavviso.

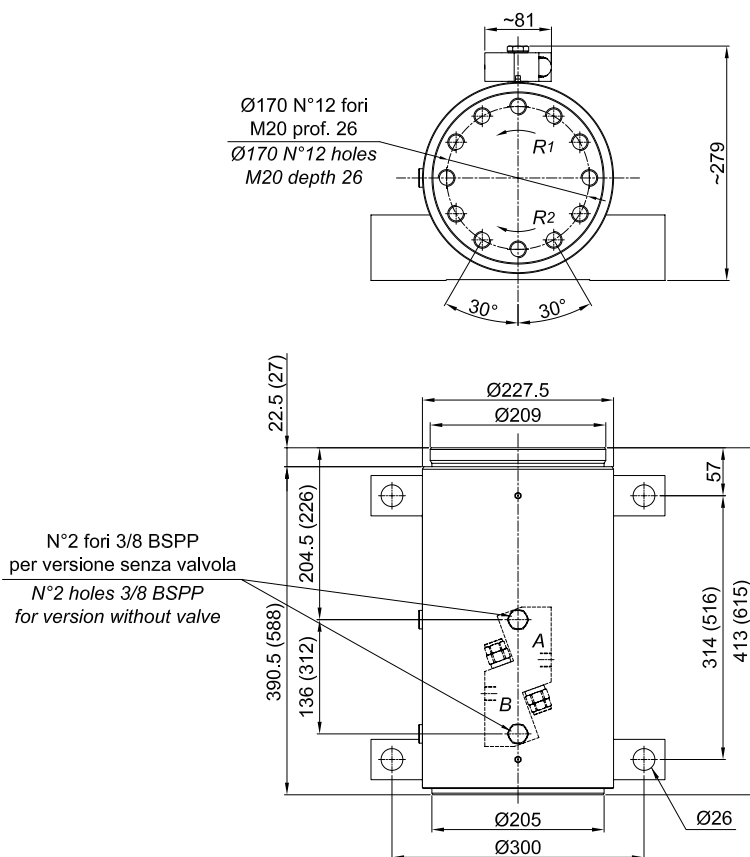

rotation	standard 180° special 360°
displacement	1722 cm ³ (3444 cm ³)
maximum drive torque at 210 bar	7600 Nm
maximum holding torque at 210 bar	10900 Nm
maximum pressure	210 bar
test pressure	320 bar
maximum thrust capacity	65000 N
maximum radial capacity	65000 N
max moment capacity straddle mounting	45000 Nm
max moment capacity cantilever mounting	20000 Nm
weight	135 kg (170 kg)
seals	PTFE- NBR - Polyurethane
working temperature	from -20°C to +80°C
overcenter valve	see specific datasheet

Data refer to the version with 180° rotation; the values in brackets are for model 360°

For more technical details please visit our site www.movecosrl.com
 Moveco can modify the technical details without notice.

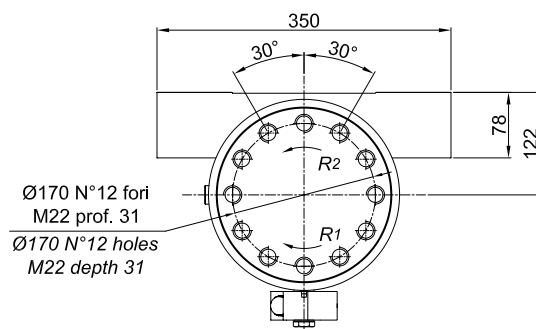

P in A / C1 = Rot. R1 P in B / C2 = Rot. R2

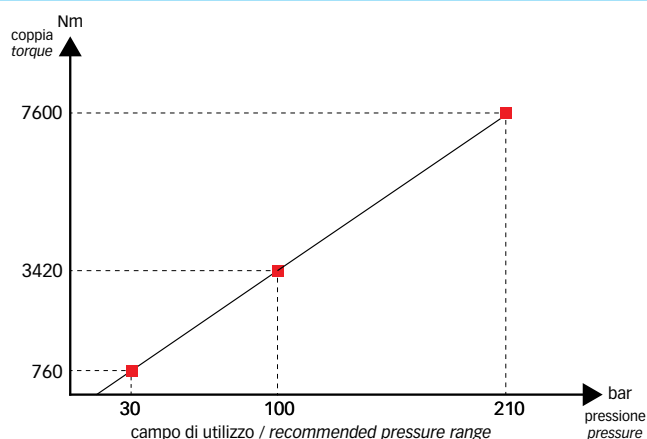

ARR 370 - RR.52/...

ATTUATORE ROTANTE
ROTARY ACTUATOR

H. MOVECO
ROTARY ACTUATORS
HYDRAULIC COMPONENTS

1

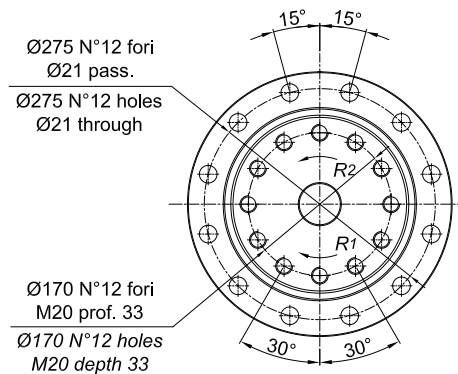

2

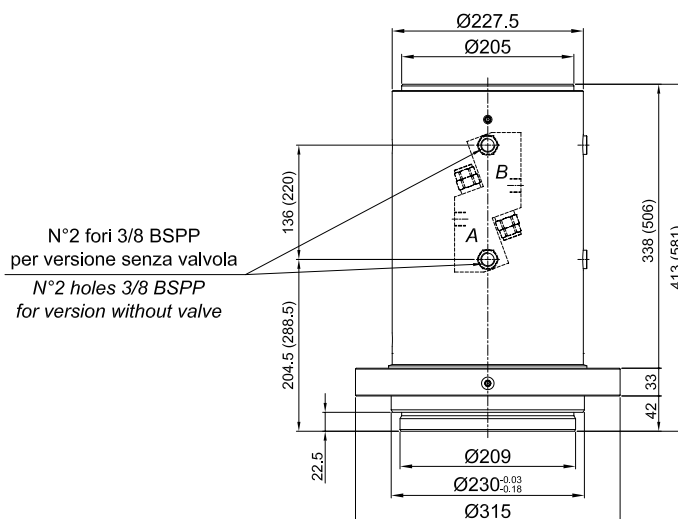

APPLICAZIONI PIU' COMUNI

Movimentazione delle teste perforanti o del braccio porta utensili su macchine da miniera o per impieghi gravosi; attuatore adatto a supportare momento ribaltante a forcella od a sbalzo; applicazione più comune ad asse orizzontale.



STANDARD APPLICATIONS

Actuator suitable to support a bending moment, cantilever straddle mounting, normally used on horizontal axle for moving of drilling heads or tool-holder arm on mining drilling machines or for heavy duty applications.





angolo di rotazione	standard 360°
cilindrata	3664 cm ³
coppia attiva massima a 210 bar	8300 Nm
coppia passiva massima a 210 bar	11900 Nm
pressione massima	210 bar
pressione di collaudo	320 bar
carico assiale massimo	36000 N
carico radiale massimo	50000 N
momento ribaltante massimo con attacco a forcella	-
momento ribaltante massimo con attacco a sbalzo	20000 Nm
peso	155 kg
materiale guarnizioni	PTFE- NBR - Poliuretano
temperatura	da -20°C a +80°C
valvola overcenter	vedi scheda relativa

Per maggiori dettagli tecnici consultate il nostro sito www.movecosrl.com
 Moveco si riserva la possibilità di apportare modifiche senza preavviso.



rotation	standard 360°
displacement	3664 cm ³
maximum drive torque at 210 bar	8300 Nm
maximum holding torque at 210 bar	11900 Nm
maximum pressure	210 bar
test pressure	320 bar
maximum thrust capacity	36000 N
maximum radial capacity	50000 N
max moment capacity straddle mounting	-
max moment capacity cantilever mounting	20000 Nm
weight	155 kg
seals	PTFE- NBR - Polyurethane
working temperature	from -20°C to +80°C
overcenter valve	see specific datasheet

For more technical details please visit our site www.movecosrl.com
 Moveco can modify the technical details without notice.

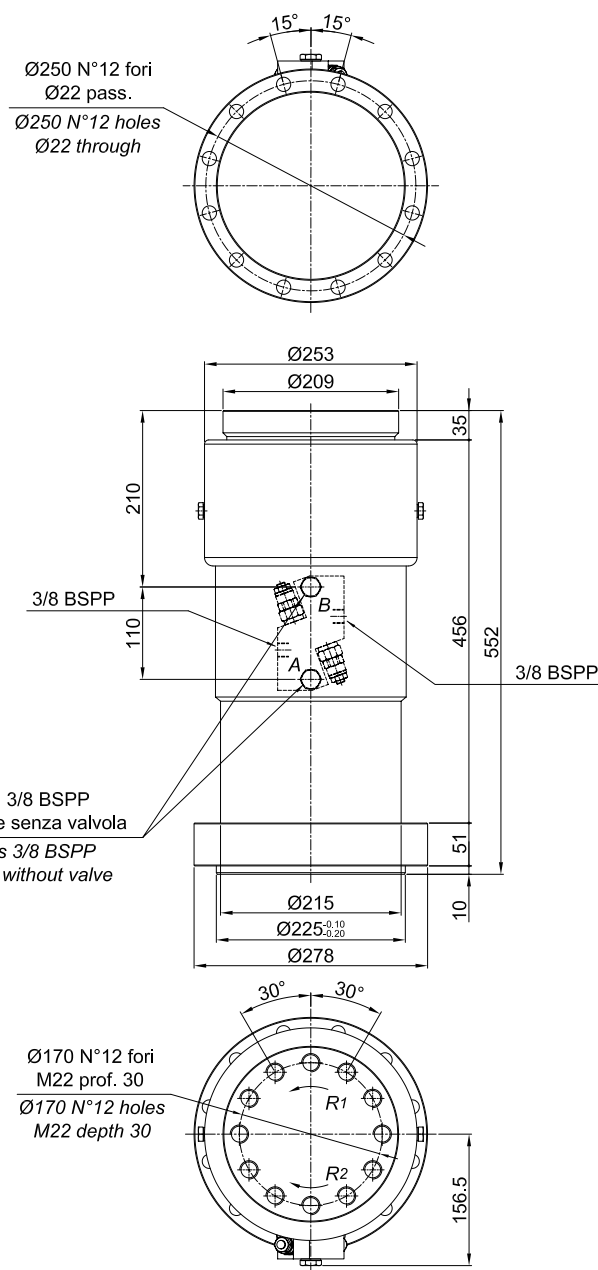

P in A / C1 = Rot. R1 P in B / C2 = Rot. R2

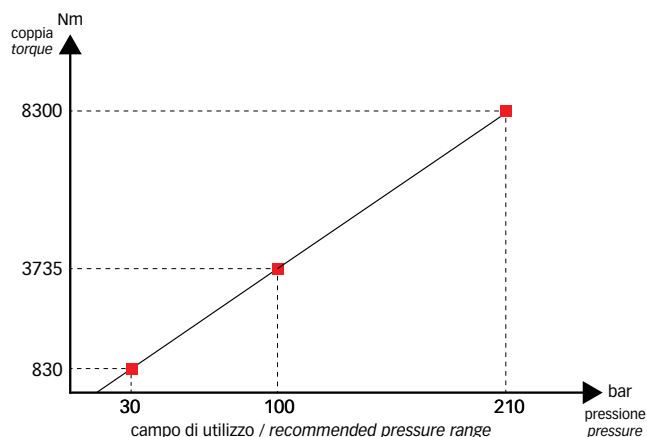

ARR 390 - RR.53/...

ATTUATORE ROTANTE
ROTARY ACTUATOR

H. MOVECO
ROTARY ACTUATORS
HYDRAULIC COMPONENTS



APPLICAZIONI PIU' COMUNI

Movimentazione delle teste perforanti o del braccio porta utensili su macchine da miniera o per impieghi gravosi; attuatore adatto a supportare momento ribaltante a forcella od a sbalzo; applicazione più comune ad asse orizzontale.



STANDARD APPLICATIONS

Actuator suitable to support a bending moment, cantilever straddle mounting, normally used on horizontal axle for moving of drilling heads or tool-holder arm on mining drilling machines or for heavy duty applications.





angolo di rotazione	standard 360°
cilindrata	5126 cm ³
coppia attiva massima a 210 bar	11500 Nm
coppia passiva massima a 210 bar	16500 Nm
pressione massima	210 bar
pressione di collaudo	320 bar
carico assiale massimo	80000 N
carico radiale massimo	100000 N
momento ribaltante massimo con attacco a forcilla	-
momento ribaltante massimo con attacco a sbalzo	35000 Nm
peso	245 kg
materiale guarnizioni	PTFE- NBR - Poliuretano
temperatura	da -20°C a +80°C
valvola overcenter	vedi scheda relativa

Per maggiori dettagli tecnici consultate il nostro sito www.movecosrl.com
 Moveco si riserva la possibilità di apportare modifiche senza preavviso.

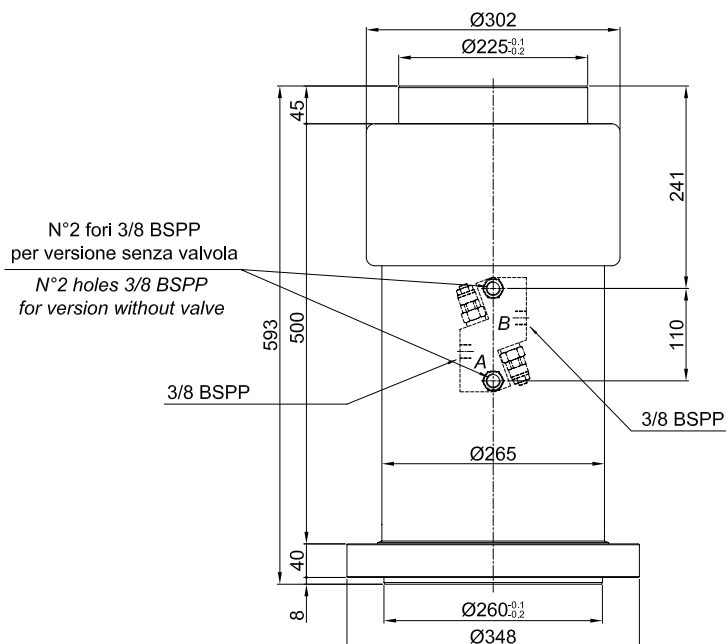

rotation	standard 360°
displacement	5126 cm ³
maximum drive torque at 210 bar	11500 Nm
maximum holding torque at 210 bar	16500 Nm
maximum pressure	210 bar
test pressure	320 bar
maximum thrust capacity	80000 N
maximum radial capacity	100000 N
max moment capacity straddle mounting	-
max moment capacity cantilever mounting	35000 Nm
weight	245 kg
seals	PTFE- NBR - Polyurethane
working temperature	from -20°C to +80°C
overcenter valve	see specific datasheet

For more technical details please visit our site www.movecosrl.com
 Moveco can modify the technical details without notice.

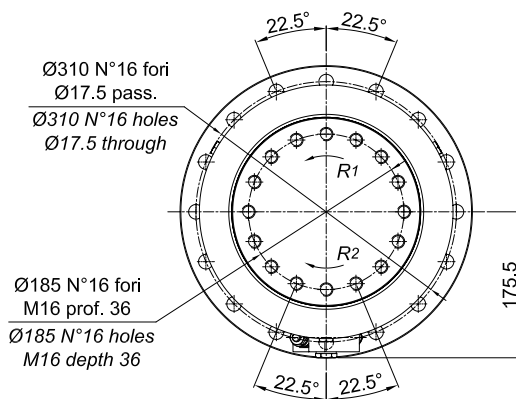

P in A / C1 = Rot. R1 P in B / C2 = Rot. R2

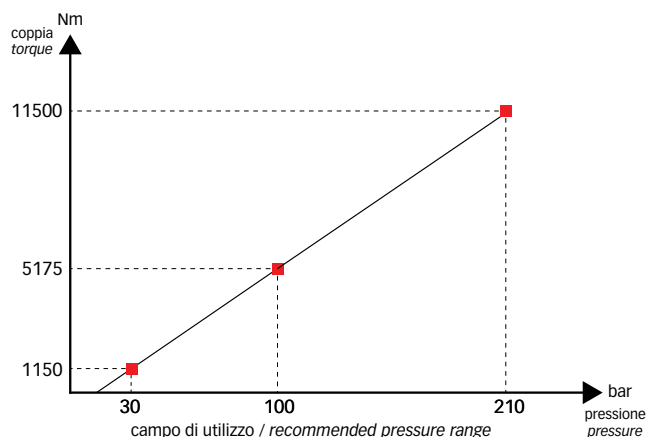

ARR 550 - RR.59/...

ATTUATORE ROTANTE
ROTARY ACTUATOR

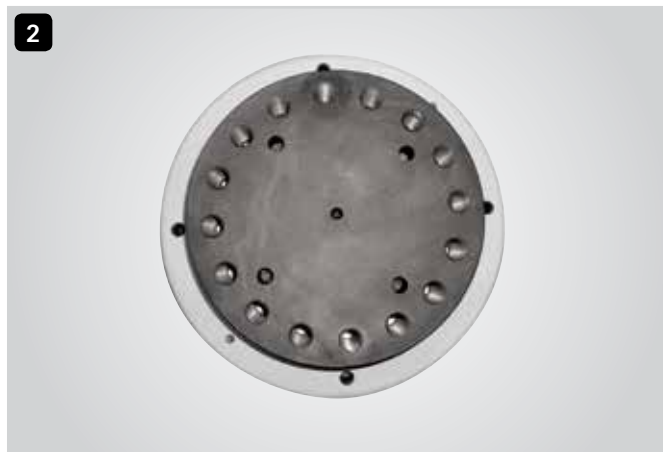

APPLICAZIONI PIU' COMUNI

Movimentazione delle teste perforanti o del braccio porta utensili su macchine da miniera o per impieghi gravosi; attuatore adatto a supportare momento ribaltante a forcella od a sbalzo; applicazione più comune ad asse orizzontale.



STANDARD APPLICATIONS

Actuator suitable to support a bending moment, cantilever or straddle mounting, normally used on horizontal axle for moving of drilling heads or tool-holder arm on mining drilling machines or for heavy duty applications.





angolo di rotazione	standard 360°
cilindrata	149 cm ³
coppia attiva massima a 210 bar	340 Nm
coppia passiva massima a 210 bar	490 Nm
pressione massima	210 bar
pressione di collaudo	320 bar
carico assiale massimo	10000 N
carico radiale massimo	3000 N
momento ribaltante massimo con attacco a forcella	-
momento ribaltante massimo con attacco a sbalzo	-
peso	9 kg
materiale guarnizioni	PTFE- NBR - Poliuretano
temperatura	da -20°C a +80°C
valvola overcenter	vedi scheda relativa

Per maggiori dettagli tecnici consultate il nostro sito www.movecosrl.com
 Moveco si riserva la possibilità di apportare modifiche senza preavviso.



rotation	standard 360°
displacement	149 cm ³
maximum drive torque at 210 bar	340 Nm
maximum holding torque at 210 bar	490 Nm
maximum pressure	210 bar
test pressure	320 bar
maximum thrust capacity	10000 N
maximum radial capacity	3000 N
max moment capacity straddle mounting	-
max moment capacity cantilever mounting	-
weight	9 kg
seals	PTFE- NBR - Polyurethane
working temperature	from -20°C to +80°C
overcenter valve	see specific datasheet

For more technical details please visit our site www.movecosrl.com
 Moveco can modify the technical details without notice.

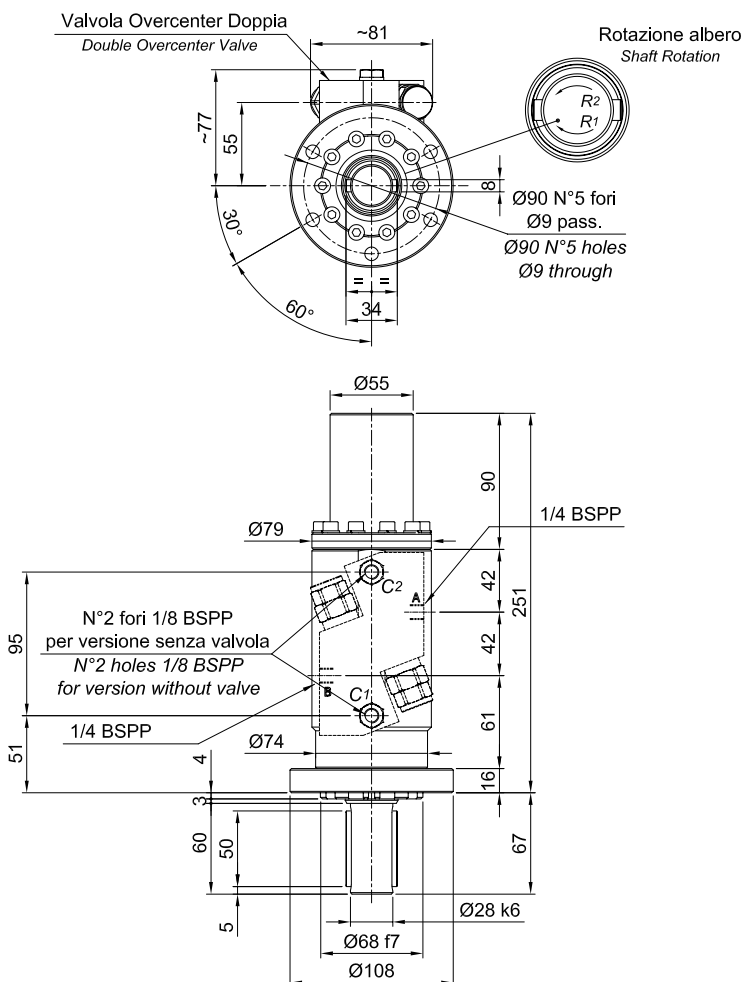

P in A / C1 = Rot. R1 P in B / C2 = Rot. R2

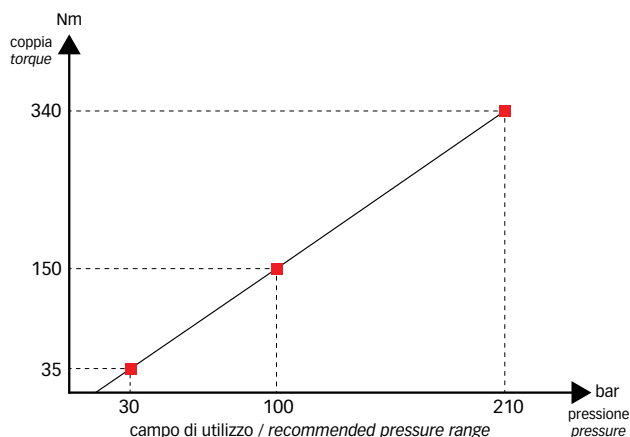

ARM 14 - RM.14/...

ATTUATORE ROTANTE
ROTARY ACTUATOR



APPLICAZIONI PIU' COMUNI

Movimentazione di tavole rotanti su macchine utensili; attuatore non adatto a supportare momento ribaltante a forcella od a sbalzo ma solamente per la coppia; applicazioni sia ad asse verticale sia orizzontale.



STANDARD APPLICATIONS

This actuator is not suitable to support any bending moment, cantilever or straddle mounting, but it gives only the torque; it is possible to use it on vertical or horizontal axle on machine-tools to move the revolving boards.

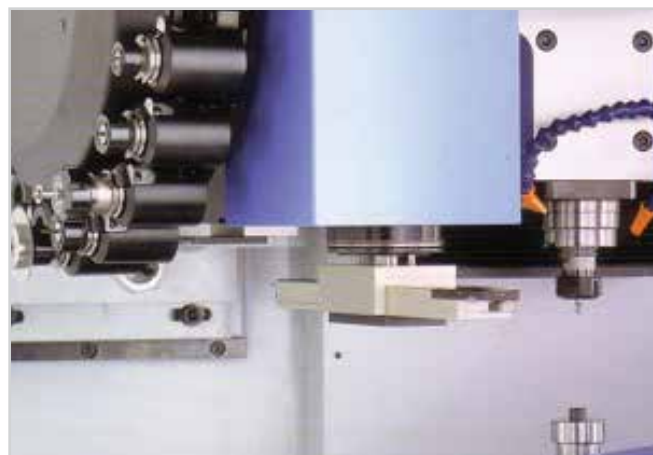



angolo di rotazione	standard 180° a richiesta: 360°
cilindrata	140 cm ³ (280 cm ³)
coppia attiva massima a 210 bar	655 Nm
coppia passiva massima a 210 bar	940 Nm
pressione massima	210 bar
pressione di collaudo	320 bar
carico assiale massimo	14000 N
carico radiale massimo	4000 N
momento ribaltante massimo con attacco a forcella	-
momento ribaltante massimo con attacco a sbalzo	-
peso	12 kg (15 kg)
materiale guarnizioni	PTFE- NBR - Poliuretano
temperatura	da -20°C a +80°C
valvola overcenter	vedi scheda relativa

I dati si riferiscono alla versione con 180° di rotazione; tra parentesi sono indicati i valori per il 360°

Per maggiori dettagli tecnici consultate il nostro sito www.movecosrl.com
 Moveco si riserva la possibilità di apportare modifiche senza preavviso.

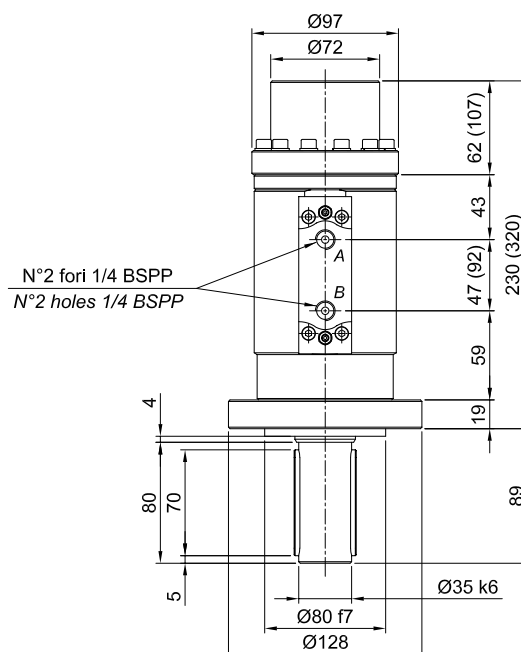
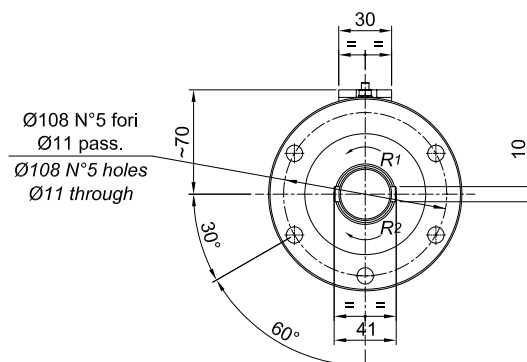

rotation	standard 180° special 360°
displacement	140 cm ³ (280 cm ³)
maximum drive torque at 210 bar	655 Nm
maximum holding torque at 210 bar	940 Nm
maximum pressure	210 bar
test pressure	320 bar
maximum thrust capacity	14000 N
maximum radial capacity	4000 N
max moment capacity straddle mounting	-
max moment capacity cantilever mounting	-
weight	12 kg (15 kg)
seals	PTFE- NBR - Polyurethane
working temperature	from -20°C to +80°C
overcenter valve	see specific datasheet

Data refer to the version with 180° rotation; the values in brackets are for model 360°

For more technical details please visit our site www.movecosrl.com
 Moveco can modify the technical details without notice.

P in A / C1 = Rot. R1 P in B / C2 = Rot. R2

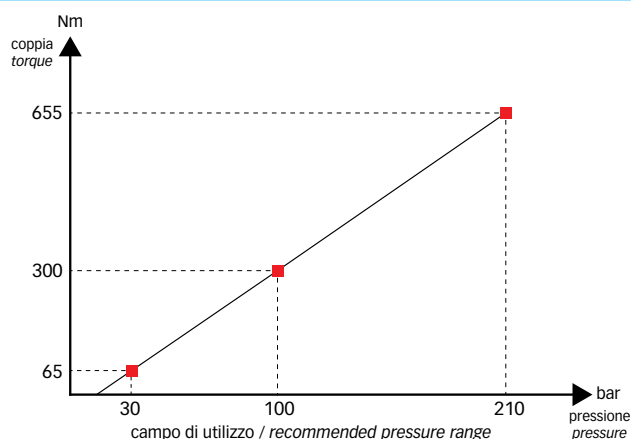

ARM 30 - RM.20/

ATTUATORE ROTANTE
ROTARY ACTUATOR

H MOVECO
ROTARY ACTUATORS
HYDRAULIC COMPONENTS



APPLICAZIONI PIU' COMUNI

Utilizzo su macchine spritz-beton per la movimentazione della lancia per calcestruzzo; attuatore non adatto a supportare momento ribaltante a forcella od a sbalzo ma solamente per la coppia; applicazioni sia ad asse verticale sia orizzontale.



STANDARD APPLICATIONS

Used on spritz-beton machines to rotate the concrete spear; this actuator is not suitable to support any bending moment, cantilever or straddle mounting, but it gives only the torque, it is possible to use it on vertical or horizontal axle.





angolo di rotazione	standard 180°
cilindrata	312 cm ³
coppia attiva massima a 210 bar	1295 Nm
coppia passiva massima a 210 bar	1850 Nm
pressione massima	210 bar
pressione di collaudo	320 bar
carico assiale massimo	14000 N
carico radiale massimo	4000 N
momento ribaltante massimo con attacco a forcilla	-
momento ribaltante massimo con attacco a sbalzo	1400 Nm
peso	21 kg
materiale guarnizioni	PTFE- NBR - Poliuretano
temperatura	da -20°C a +80°C
valvola overcenter	vedi scheda relativa

Per maggiori dettagli tecnici consultate il nostro sito www.movecosrl.com
 Moveco si riserva la possibilità di apportare modifiche senza preavviso.

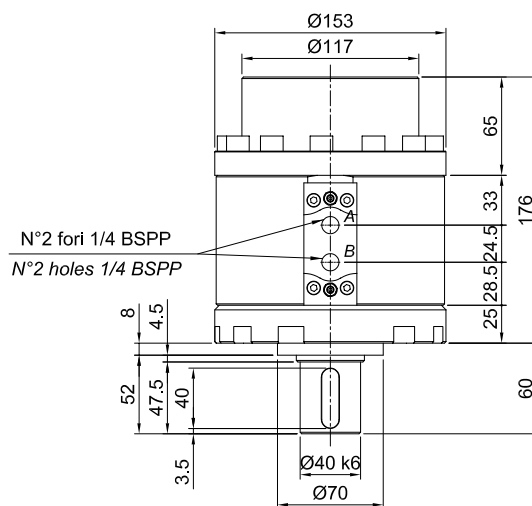
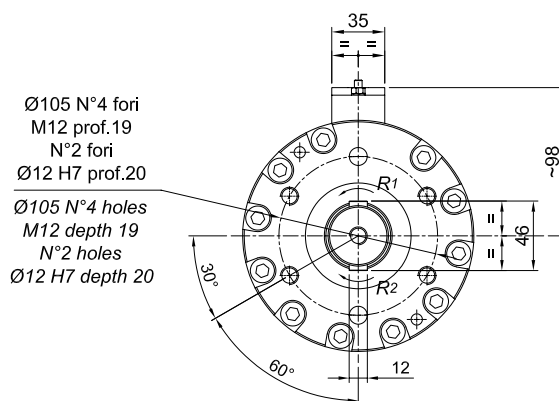

P in A / C1 = Rot. R1 P in B / C2 = Rot. R2

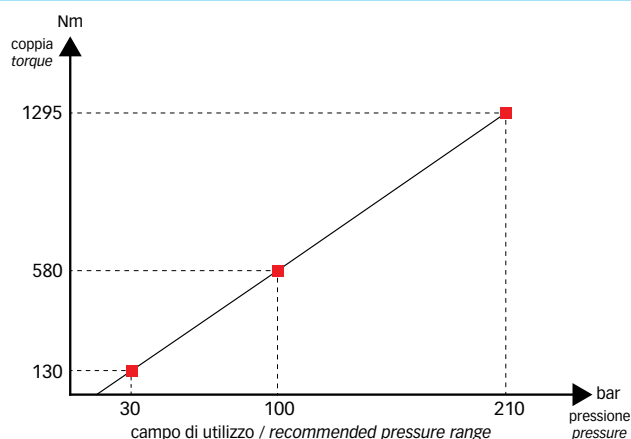

rotation	standard 180°
displacement	312 cm ³
maximum drive torque at 210 bar	1295 Nm
maximum holding torque at 210 bar	1850 Nm
maximum pressure	210 bar
test pressure	320 bar
maximum thrust capacity	14000 N
maximum radial capacity	4000 N
max moment capacity straddle mounting	-
max moment capacity cantilever mounting	1400 Nm
weight	21 kg
seals	PTFE- NBR - Polyurethane
working temperature	from -20°C to +80°C
overcenter valve	see specific datasheet

For more technical details please visit our site www.movecosrl.com
 Moveco can modify the technical details without notice.

ARM 60 - RM.28/...

ATTUATORE ROTANTE
ROTARY ACTUATOR

H. MOVECO
ROTARY ACTUATORS
HYDRAULIC COMPONENTS



APPLICAZIONI PIU' COMUNI

Utilizzo su macchine spritz-beton per la movimentazione della lancia per calcestruzzo; attuatore non adatto a supportare momento ribaltante a forcella od a sbalzo ma solamente per la coppia; applicazioni sia ad asse verticale sia orizzontale.



STANDARD APPLICATIONS

Used on spritz-beton machines to rotate the concrete spear; this actuator is not suitable to support any bending moment, cantilever or straddle mounting, but it gives only the torque, it is possible to use it on vertical or horizontal axle.





angolo di rotazione	standard 180° a richiesta: 360°
cilindrata	289 cm ³ (579 cm ³)
coppia attiva massima a 210 bar	1350 Nm
coppia passiva massima a 210 bar	1930 Nm
pressione massima	210 bar
pressione di collaudo	320 bar
carico assiale massimo	19000 N
carico radiale massimo	7500 N
momento ribaltante massimo con attacco a forcella	-
momento ribaltante massimo con attacco a sbalzo	-
peso	21 kg (26 kg)
materiale guarnizioni	PTFE- NBR - Poliuretano
temperatura	da -20°C a +80°C
valvola overcenter	vedi scheda relativa

I dati si riferiscono alla versione con 180° di rotazione; tra parentesi sono indicati i valori per il 360°

Per maggiori dettagli tecnici consultate il nostro sito www.movecosrl.com
 Moveco si riserva la possibilità di apportare modifiche senza preavviso.



rotation	standard 180° special 360°
displacement	289 cm ³ (579 cm ³)
maximum drive torque at 210 bar	1350 Nm
maximum holding torque at 210 bar	1930 Nm
maximum pressure	210 bar
test pressure	320 bar
maximum thrust capacity	19000 N
maximum radial capacity	7500 N
max moment capacity straddle mounting	-
max moment capacity cantilever mounting	-
weight	21 kg (26 kg)
seals	PTFE- NBR - Polyurethane
working temperature	from -20°C to +80°C
overcenter valve	see specific datasheet

Data refer to the version with 180° rotation; the values in brackets are for model 360°

For more technical details please visit our site www.movecosrl.com
 Moveco can modify the technical details without notice.

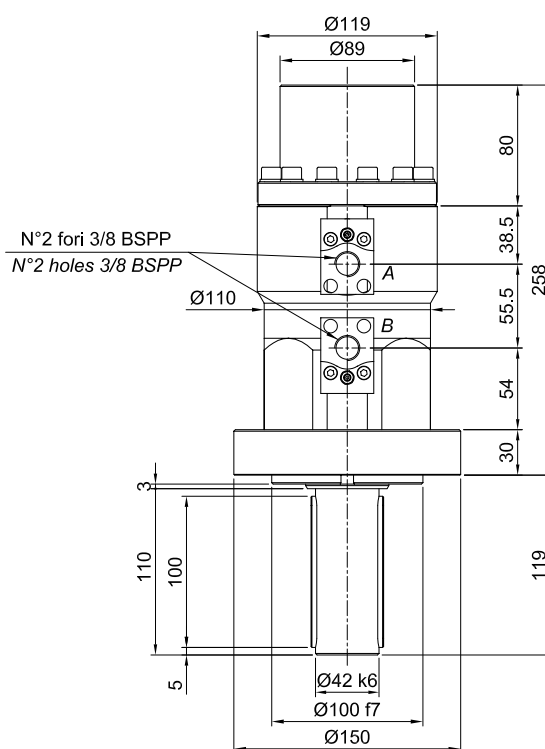
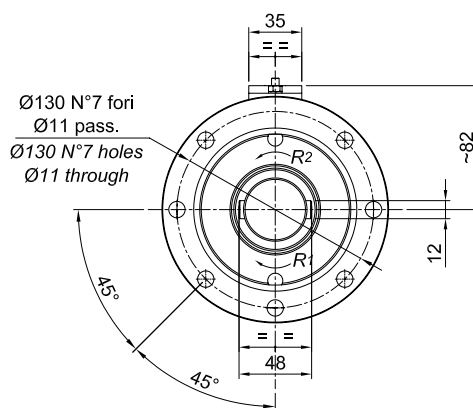

P in A / C1 = Rot. R1 P in B / C2 = Rot. R2

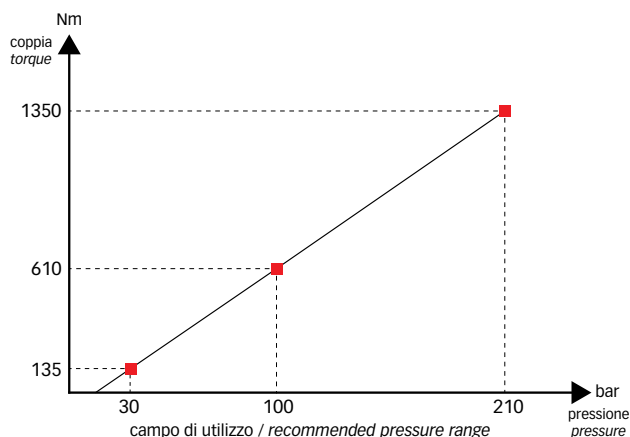

ARM 64 - RM.29/...

ATTUATORE ROTANTE
ROTARY ACTUATOR



APPLICAZIONI PIU' COMUNI

Movimentazione bracci od utensili vari per impieghi nel campo agricolo o stradale; attuatore non adatto a supportare momento ribaltante a forcella od a sbalzo ma solamente per la coppia; applicazioni sia ad asse verticale sia orizzontale.



STANDARD APPLICATIONS

Actuator not suitable to support a bending moment, cantilever or straddle mounting, but only to give the torque; applications both on vertical and horizontal axle for moving arms and various tools on machineries for communal and agriculture fields.





angolo di rotazione	standard 180°
cilindrata	554 cm ³
coppia attiva massima a 210 bar	2555 Nm
coppia passiva massima a 210 bar	3650 Nm
pressione massima	210 bar
pressione di collaudo	320 bar
carico assiale massimo	25000 N
carico radiale massimo	12000 N
momento ribaltante massimo con attacco a forcella	-
momento ribaltante massimo con attacco a sbalzo	-
peso	30 kg
materiale guarnizioni	PTFE- NBR - Poliuretano
temperatura	da -20°C a +80°C
valvola overcenter	vedi scheda relativa

Per maggiori dettagli tecnici consultate il nostro sito www.movecosrl.com
 Moveco si riserva la possibilità di apportare modifiche senza preavviso.



rotation	standard 180°
displacement	554 cm ³
maximum drive torque at 210 bar	2555 Nm
maximum holding torque at 210 bar	3650 Nm
maximum pressure	210 bar
test pressure	320 bar
maximum thrust capacity	25000 N
maximum radial capacity	12000 N
max moment capacity straddle mounting	-
max moment capacity cantilever mounting	-
weight	30 kg
seals	PTFE- NBR - Polyurethane
working temperature	from -20°C to +80°C
overcenter valve	see specific datasheet

For more technical details please visit our site www.movecosrl.com
 Moveco can modify the technical details without notice.

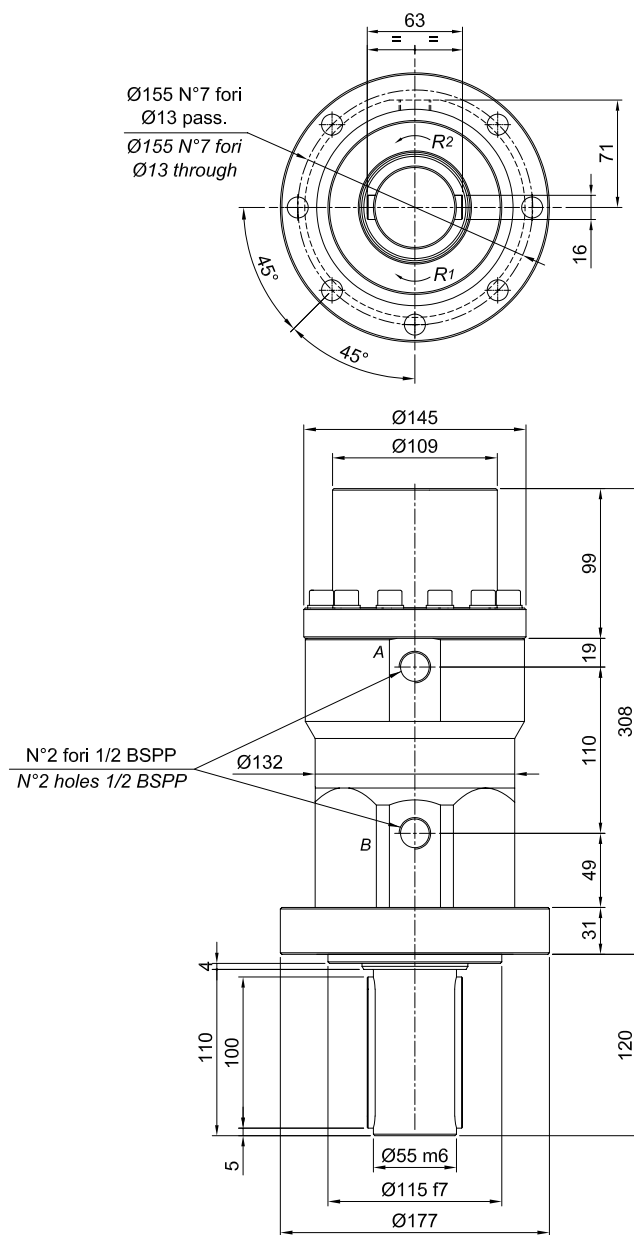

P in A / C1 = Rot. R1 P in B / C2 = Rot. R2

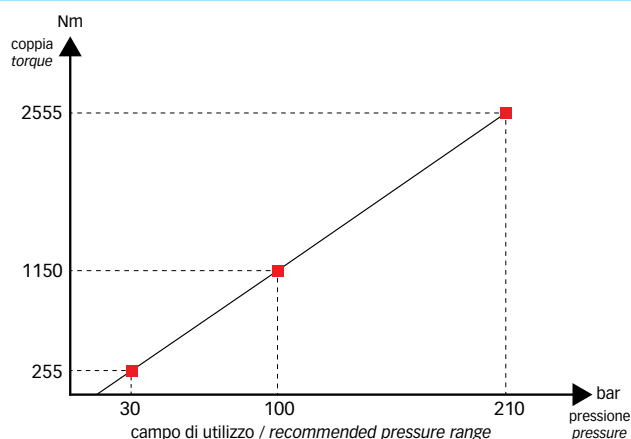

ARM 115 - RM.37/...

ATTUATORE ROTANTE
ROTARY ACTUATOR



APPLICAZIONI PIU' COMUNI

Movimentazione bracci od utensili vari per impieghi nel campo agricolo o stradale; attuatore non adatto a supportare momento ribaltante a forcella od a sbalzo ma solamente per la coppia; applicazioni sia ad asse verticale sia orizzontale.



STANDARD APPLICATIONS

Actuator not suitable to support a bending moment, cantilever or straddle mounting, but only to give the torque; applications both on vertical and horizontal axle for moving arms and various tools on machineries for communal and agriculture fields.





angolo di rotazione	standard 90°
cilindrata	473 cm ³
coppia attiva massima a 210 bar	4575 Nm
coppia passiva massima a 210 bar	6540 Nm
pressione massima	210 bar
pressione di collaudo	320 bar
carico assiale massimo	-
carico radiale massimo	-
momento ribaltante massimo con attacco a forcella	-
momento ribaltante massimo con attacco a sbalzo	-
peso	42 kg
materiale guarnizioni	PTFE- NBR - Poliuretano
temperatura	da -20°C a +80°C
valvola overcenter	vedi scheda relativa

Per maggiori dettagli tecnici consultate il nostro sito www.movecosrl.com
 Moveco si riserva la possibilità di apportare modifiche senza preavviso.

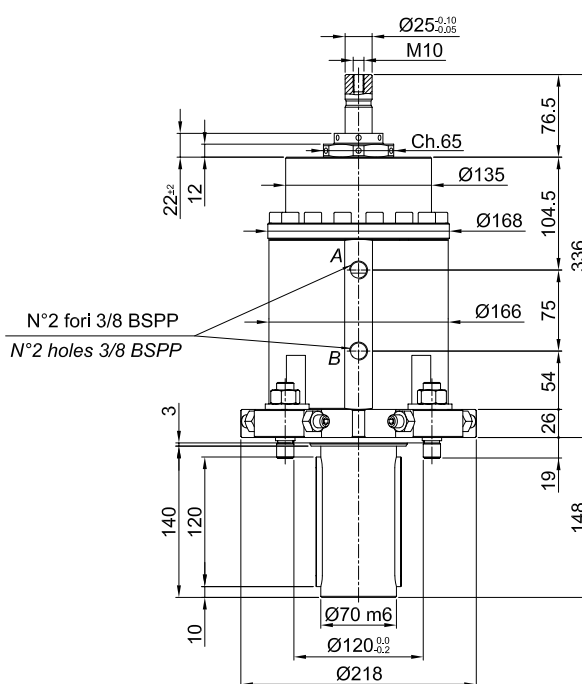
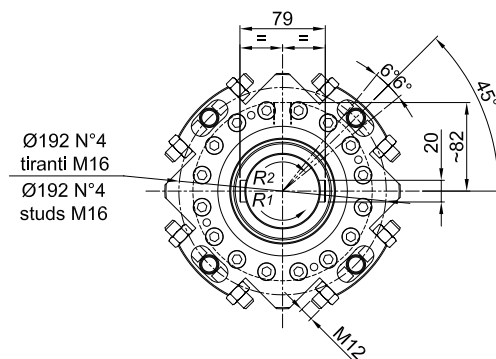

rotation	standard 90°
displacement	473 cm ³
maximum drive torque at 210 bar	4575 Nm
maximum holding torque at 210 bar	6540 Nm
maximum pressure	210 bar
test pressure	320 bar
maximum thrust capacity	-
maximum radial capacity	-
max moment capacity straddle mounting	-
max moment capacity cantilever mounting	-
weight	42 kg
seals	PTFE- NBR - Polyurethane
working temperature	from -20°C to +80°C
overcenter valve	see specific datasheet

For more technical details please visit our site www.movecosrl.com
 Moveco can modify the technical details without notice.

P in A / C1 = Rot. R1 P in B / C2 = Rot. R2

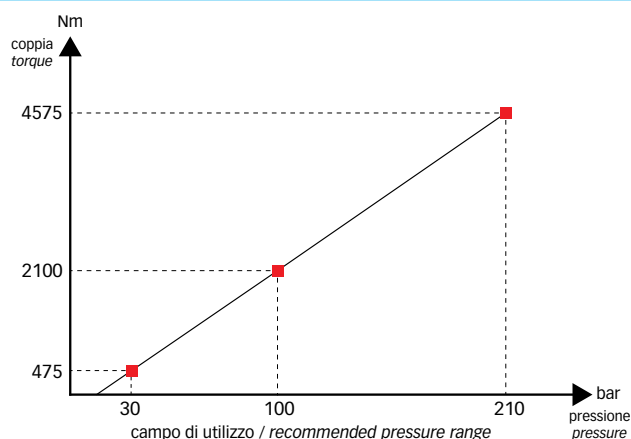

ARM 210 - RM.44/...

ATTUATORE ROTANTE
ROTARY ACTUATOR

H MOVECO
ROTARY ACTUATORS
HYDRAULIC COMPONENTS

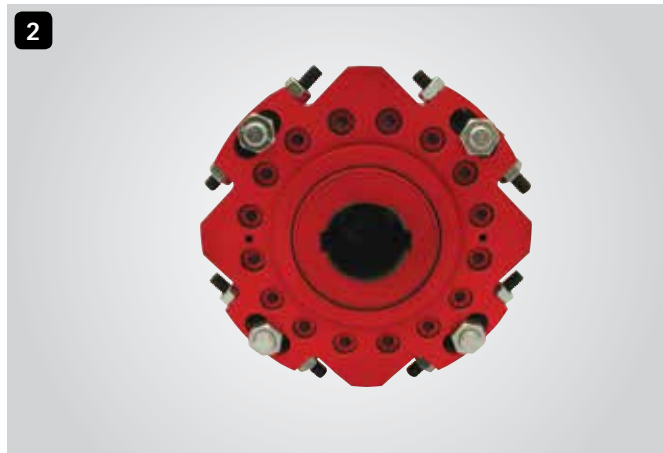

APPLICAZIONI PIU' COMUNI

Apertura e chiusura di portelli laterali o di poppa su barche di varia dimensione; attuatore non adatto a supportare momento ribaltante a forcella od a sbalzo ma solamente per la coppia; applicazioni sia ad asse verticale sia orizzontale.



STANDARD APPLICATIONS

This actuator is not suitable to support any bending moment, cantilever or straddle mounting, but it is used only for the torque; it can be placed on horizontal or vertical axle; applications: opening and shutting of side and stern doors on boats with different dimensions.





angolo di rotazione	standard 180°
cilindrata	1217 cm ³
coppia attiva massima a 210 bar	5700 Nm
coppia passiva massima a 210 bar	8150 Nm
pressione massima	210 bar
pressione di collaudo	320 bar
carico assiale massimo	35000 N
carico radiale massimo	18000 N
momento ribaltante massimo con attacco a forcella	-
momento ribaltante massimo con attacco a sbalzo	-
peso	59 kg
materiale guarnizioni	PTFE- NBR - Poliuretano
temperatura	da -20°C a +80°C
valvola overcenter	vedi scheda relativa

Per maggiori dettagli tecnici consultate il nostro sito www.movecosrl.com
 Moveco si riserva la possibilità di apportare modifiche senza preavviso.



rotation	standard 180°
displacement	1217 cm ³
maximum drive torque at 210 bar	5700 Nm
maximum holding torque at 210 bar	8150 Nm
maximum pressure	210 bar
test pressure	320 bar
maximum thrust capacity	35000 N
maximum radial capacity	18000 N
max moment capacity straddle mounting	-
max moment capacity cantilever mounting	-
weight	59 kg
seals	PTFE- NBR - Polyurethane
working temperature	from -20°C to +80°C
overcenter valve	see specific datasheet

For more technical details please visit our site www.movecosrl.com
 Moveco can modify the technical details without notice.

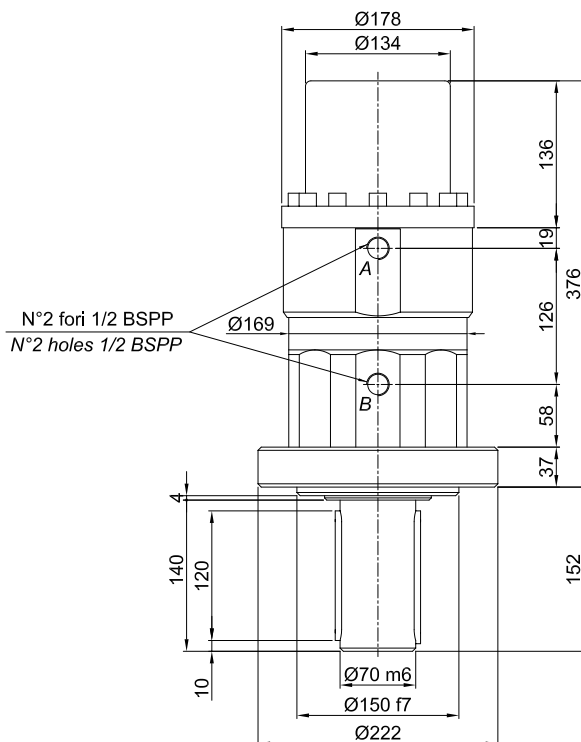
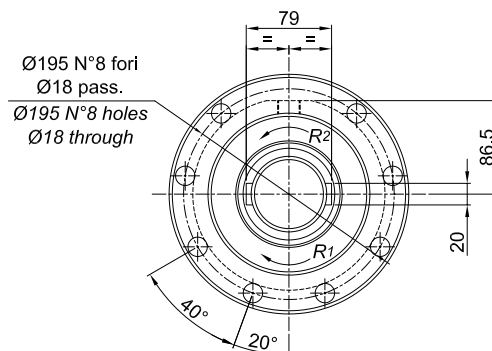

P in A / C1 = Rot. R1 P in B / C2 = Rot. R2

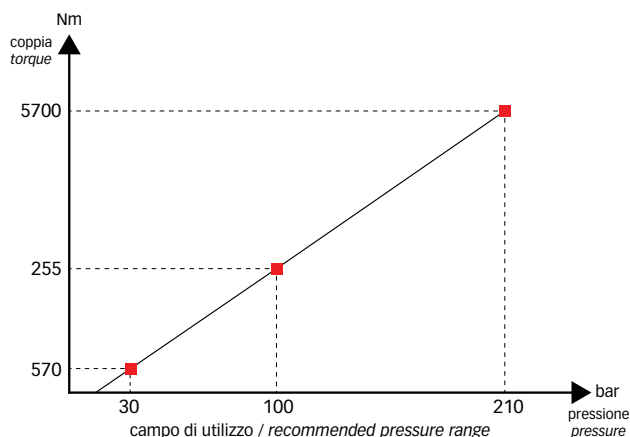

ARM 250 - RM.48/...

ATTUATORE ROTANTE
ROTARY ACTUATOR



APPLICAZIONI PIU' COMUNI

Apertura e chiusura di portelli laterali o di poppa su barche di varia dimensione e per la movimentazione di tavole rotanti su macchine utensili; attuatore non adatto a supportare momento ribaltante a forcella od a sbalzo ma solamente per la coppia; applicazioni sia ad asse verticale sia orizzontale.



STANDARD APPLICATIONS

This actuator is not suitable to support any bending moment, cantilever or straddle mounting, but it is used only for the torque; it can be placed on horizontal or vertical axle; applications: opening and shutting of side and stern doors on boats with different dimensions.





angolo di rotazione	standard 180°
cilindrata	1758 cm ³
coppia attiva massima a 210 bar	8200 Nm
coppia passiva massima a 210 bar	11750 Nm
pressione massima	210 bar
pressione di collaudo	320 bar
carico assiale massimo	41000 N
carico radiale massimo	21000 N
momento ribaltante massimo con attacco a forcella	-
momento ribaltante massimo con attacco a sbalzo	-
peso	86 kg
materiale guarnizioni	PTFE- NBR - Poliuretano
temperatura	da -20°C a +80°C
valvola overcenter	vedi scheda relativa

Per maggiori dettagli tecnici consultate il nostro sito www.movecosrl.com
 Moveco si riserva la possibilità di apportare modifiche senza preavviso.



rotation	standard 180°
displacement	1758 cm ³
maximum drive torque at 210 bar	8200 Nm
maximum holding torque at 210 bar	11750 Nm
maximum pressure	210 bar
test pressure	320 bar
maximum thrust capacity	41000 N
maximum radial capacity	21000 N
max moment capacity straddle mounting	-
max moment capacity cantilever mounting	-
weight	86 kg
seals	PTFE- NBR - Polyurethane
working temperature	from -20°C to +80°C
overcenter valve	see specific datasheet

For more technical details please visit our site www.movecosrl.com
 Moveco can modify the technical details without notice.

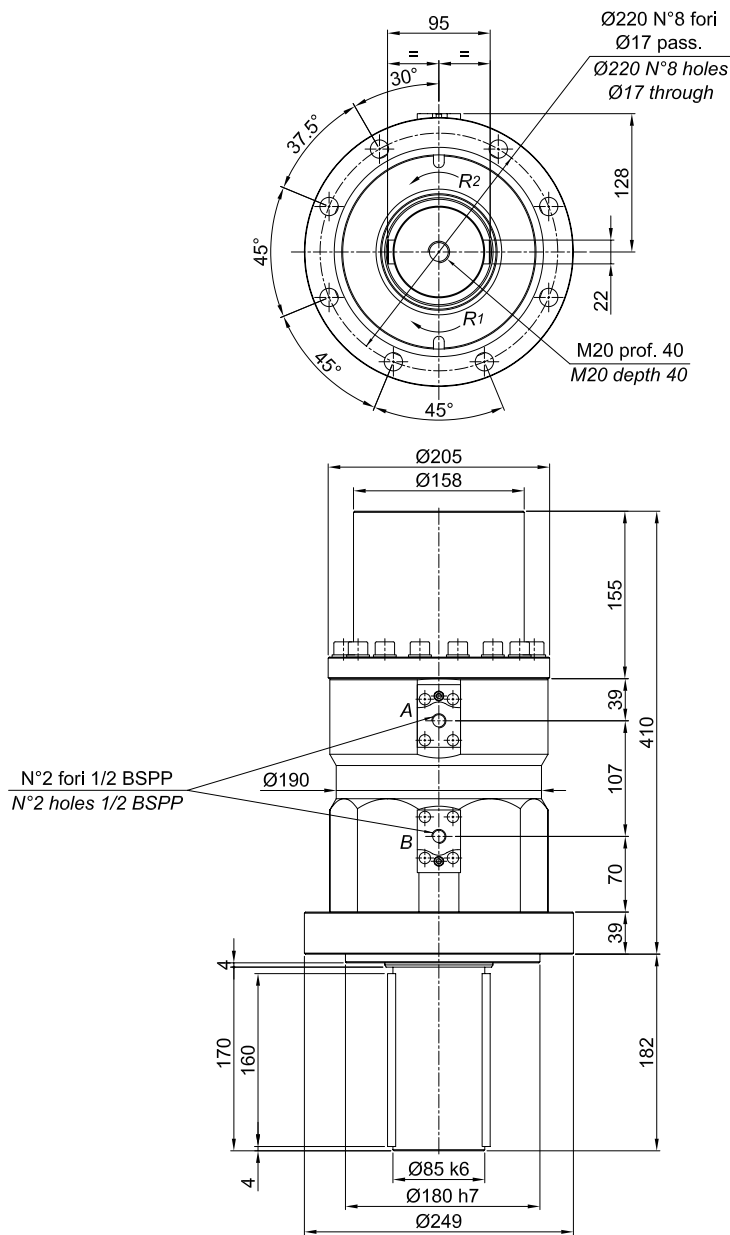

P in A / C1 = Rot. R1 P in B / C2 = Rot. R2

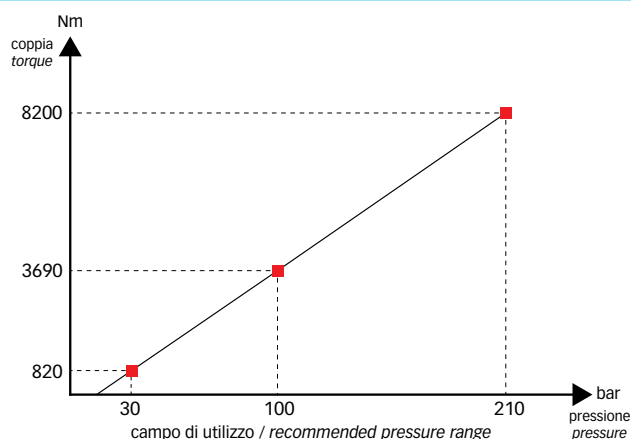

ARM 390 - RM.53/...

ATTUATORE ROTANTE
ROTARY ACTUATOR

H MOVECO
ROTARY ACTUATORS
HYDRAULIC COMPONENTS



APPLICAZIONI PIU' COMUNI

Apertura e chiusura di portelli laterali o di poppa su barche di varia dimensione e per la movimentazione di tavole rotanti su macchine utensili; attuatore non adatto a supportare momento ribaltante a forcella od a sbalzo ma solamente per la coppia; applicazioni sia ad asse verticale sia orizzontale.



STANDARD APPLICATIONS

This actuator is not suitable to support any bending moment, cantilever or straddle mounting, but it is used only for the torque; it can be placed on horizontal or vertical axle; applications: opening and shutting of side and stern doors on boats with different dimensions.





angolo di rotazione	standard 180°
cilindrata	4760 cm ³
coppia attiva massima a 210 bar	22200 Nm
coppia passiva massima a 210 bar	31750 Nm
pressione massima	210 bar
pressione di collaudo	320 bar
carico assiale massimo	62000 N
carico radiale massimo	67000 N
momento ribaltante massimo con attacco a forcella	-
momento ribaltante massimo con attacco a sbalzo	-
peso	215 kg
materiale guarnizioni	PTFE- NBR - Poliuretano
temperatura	da -20°C a +80°C
valvola overcenter	vedi scheda relativa

Per maggiori dettagli tecnici consultate il nostro sito www.movecosrl.com
 Moveco si riserva la possibilità di apportare modifiche senza preavviso.



rotation	standard 180°
displacement	4760 cm ³
maximum drive torque at 210 bar	22200 Nm
maximum holding torque at 210 bar	31750 Nm
maximum pressure	210 bar
test pressure	320 bar
maximum thrust capacity	62000 N
maximum radial capacity	67000 N
max moment capacity straddle mounting	-
max moment capacity cantilever mounting	-
weight	215 kg
seals	PTFE- NBR - Polyurethane
working temperature	from -20°C to +80°C
overcenter valve	see specific datasheet

For more technical details please visit our site www.movecosrl.com
 Moveco can modify the technical details without notice.

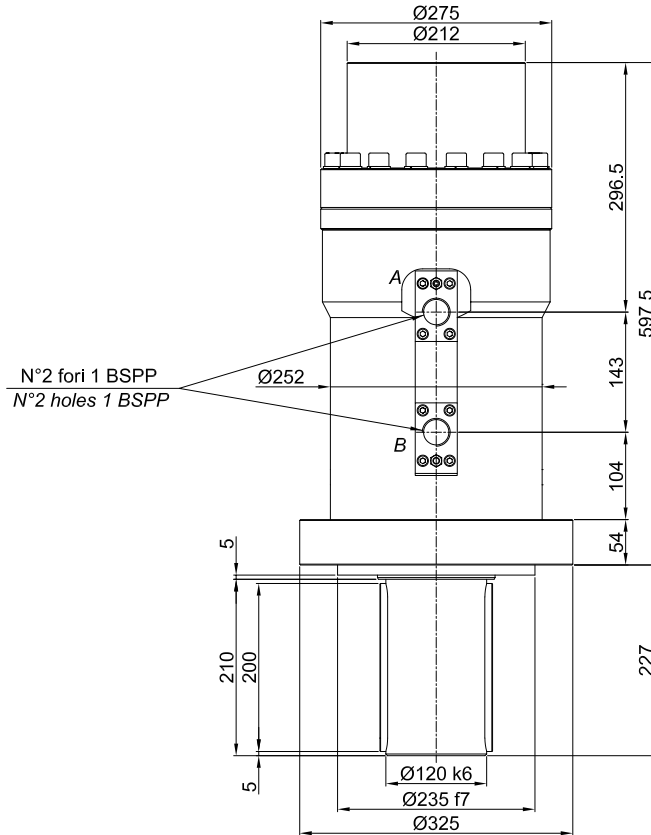
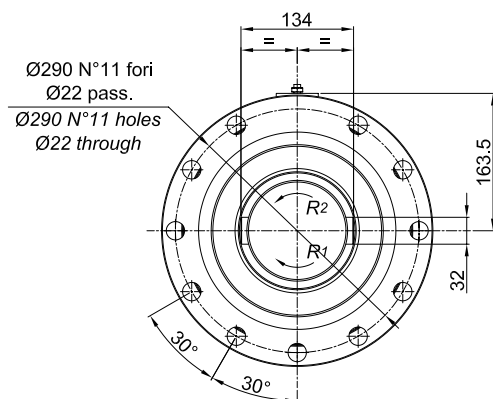

P in A / C1 = Rot. R1 P in B / C2 = Rot. R2

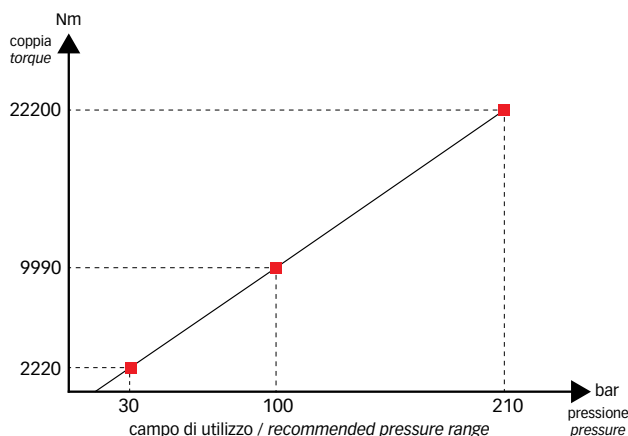

ARM 1000 - RM.67/...

ATTUATORE ROTANTE
ROTARY ACTUATOR

H. MOVECO
ROTARY ACTUATORS
HYDRAULIC COMPONENTS



APPLICAZIONI PIU' COMUNI

Apertura e chiusura di portelli laterali o di poppa su barche di varia dimensione; attuatore non adatto a supportare momento ribaltante a forcella od a sbalzo ma solamente per la coppia; applicazioni sia ad asse verticale sia orizzontale.



STANDARD APPLICATIONS

This actuator is not suitable to support any bending moment, cantilever or straddle mounting, but it is used only for the torque; it can be placed on horizontal or vertical axle; applications: opening and shutting of side and stern doors on boats with different dimensions.

